

2. Masking Text

Continue working on the **RETWALL** drawing. Make all layers visible again. *Move* the 4 text objects labeling the hatch patterns to a location inside each hatch pattern and *Erase* the *Leader* (Fig. 47-3). In order to make the text readable, use the *Textmask* command to mask the hatch patterns behind the text objects. *SaveAs* CE47-2.

Figure CE47-3

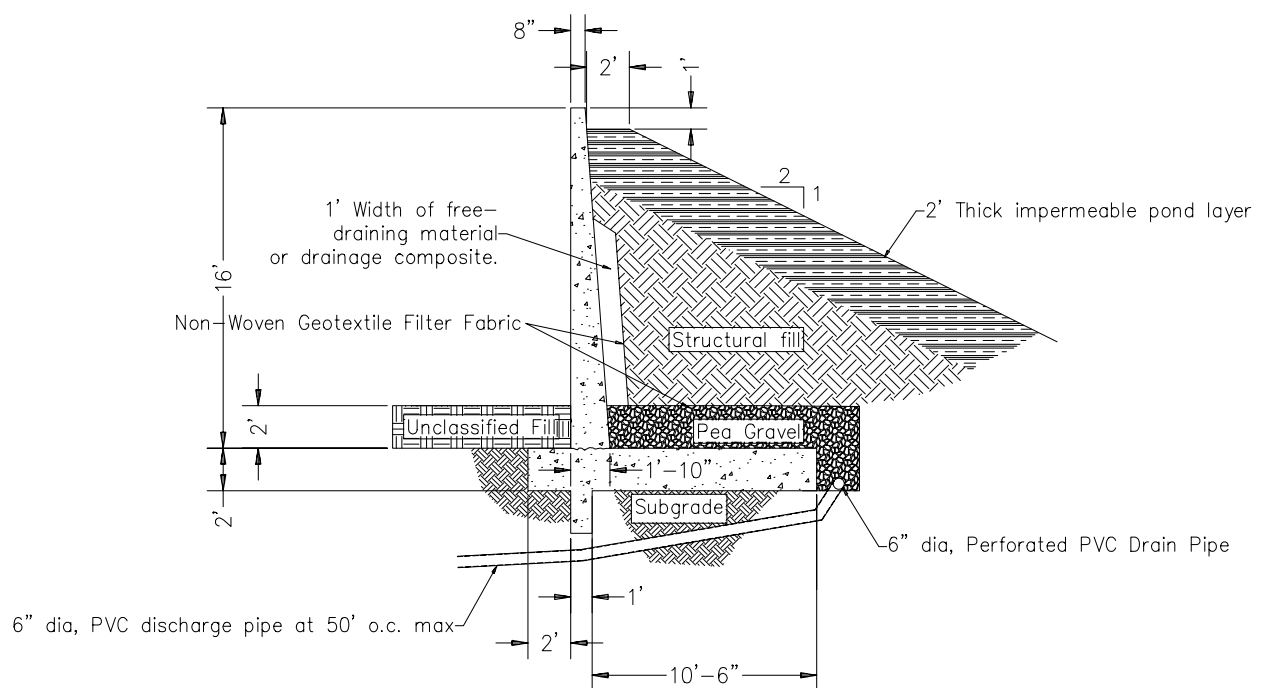

3. Synchronizing Viewports

Open the **FRAMING** drawing from the Chapter 33 Exercises. Notice that the viewports for the two detail views are not aligned. The Express Tools provide a simple way to line up the views between two different model space viewports while in the *Layout* tab. Select *Layout Tools* from the *Express* pull-down menu. Activate the *Synchronize Viewports* command and select the two viewports you wish to align (note: you will have to select on the viewport frame so make sure that it is not frozen or off before executing this command). *SaveAs* CE47-3.

4. Revision Bubble

Open the CE29EX1 drawing from the Chapter 29 Exercises. *Stretch* the front porch to a new length of 17'-8". Create a new *Layer* called **REV** and draw a revision cloud on it as shown in Figure CE47-4. *SaveAs* CE47EX4.

Figure CE47-4

