CHAPTER 11

Data Link Control and Protocols

Review Questions

1. Flow control prevents the receiving device from being overwhelmed with data.
3. The frame is re-transmitted.
5. In Selective Repeat ARQ, just the damaged frame is re-transmitted. In Go-Back-N ARQ, all frames starting with the damaged frame are re-transmitted.
7. At the sender site the window size is at most $2^m - 1$. At the receiver site the window size is always 1.
9. Both the sender site window and the receiver site window are at most one-half of 2^m .
11. The bandwidth delay product is a measure of the number of bits that can be sent out while waiting for news from the receiver.
13. I-frames are used to transport user data and related control information. S-frames carry control information (data link flow and error control). U-frames are used to transport system management information.
15. Piggybacking is combining data to be sent and acknowledgment of the received frame in one single frame.

Multiple-Choice Questions

17. a
19. d
21. b
23. a
25. b
27. a
29. b

Exercises

31. See Figure 11.1.

Figure 11.1 Exercise 31

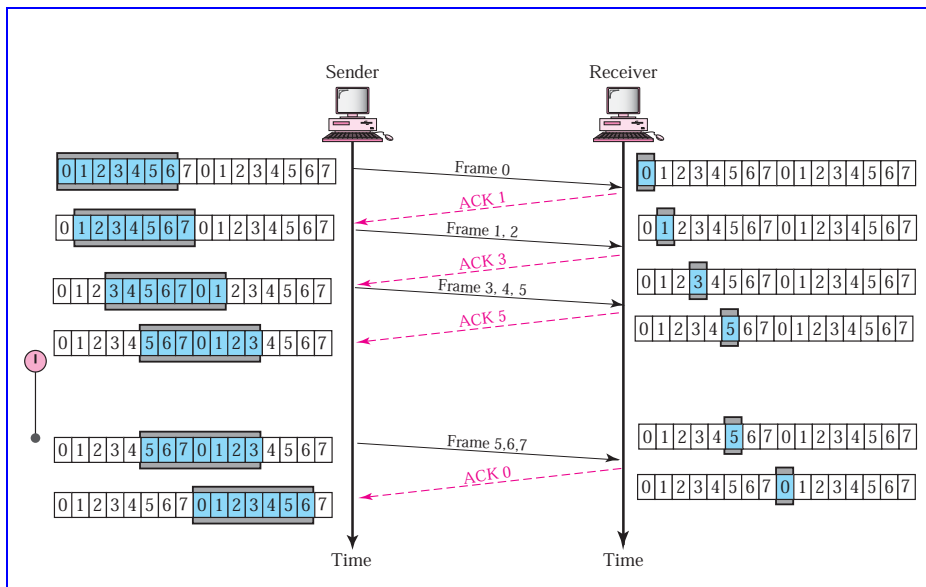

33. The number refers to the damaged frame; only that frame should be resent.

35.

- a. Frames 7 and 0 received; next frame expected is frame 1
- b. Frames 7, 0, 1, 2, and 3 received; next frame expected is frame 4
- c. Frames 7, 0, 1, 2 received; the next frame expected is frame 3

37. 127.

39. Window size is 15.

41. 80 μ s

43. less than 6 ms

45. \leftarrow 0001111101111101111101111101111101111100111110001