

GUIDED TOUR

Welcome to AutoCAD 2004 Instructor. Here are some features you will find in this book to help you learn AutoCAD 2004.

Chapter Objectives

Each chapter opens with a list of new concepts you can expect to learn. Having objectives in mind helps you focus on the important ideas as you move through each chapter.

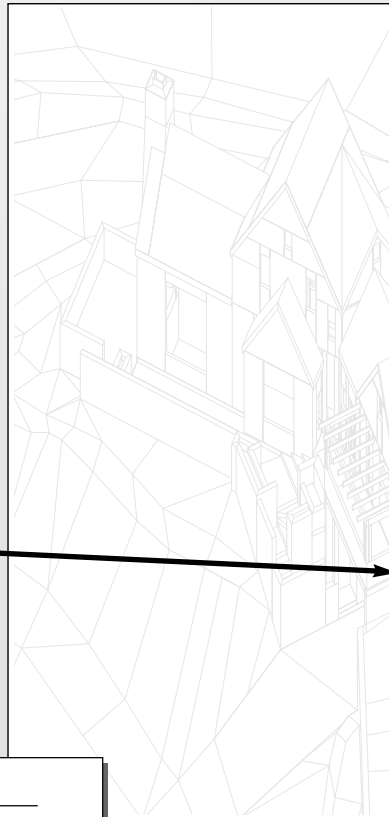

9

MODIFY COMMANDS I

Chapter Objectives

After completing this chapter you should:

1. be able to *Erase* objects;
2. be able to *Move* objects from a base point to a second point;
3. know how to *Rotate* objects about a base point;
4. be able to enlarge or reduce objects with *Scale*;
5. be able to *Stretch* objects and change the length of *Lines* and *Arcs* with *Lengthen*;
6. be able to *Trim* away parts of objects at cutting edges and *Extend* objects to boundary edges;
7. know how to use the four *Break* options;
8. be able to *Copy* objects and make *Mirror* images of selected objects;
9. know how to create parallel copies of objects with *Offset*;
10. be able to make *rectangular* and *polar Arrays* of objects;
11. be able to create a *Fillet* and a *Chamfer* between two objects.

78 Selection Sets

Using Move

The *Move* command specifically prompts you to (1) select objects, (2) specify a "base point," a point to move *from*, and (3) specify a "second point of displacement," a point to move *to*.

MOVE

Pull-down Menu	COMMAND (TYPE)	ALIAS (TYPE)	Short-cut	Screen (side) Menu	Tablet Menu
 <i>Modify Move</i>	MOVE	M	(Edit Mode) <i>Move</i>	MODIFY2 <i>Move</i>	V19

1. Draw a *Circle* and two *Lines*. Use the *Move* command to practice selecting objects and to move one *Line* and the *Circle* as indicated in the following table.

STEPS	COMMAND PROMPT	PERFORM ACTION	COMMENTS
1.	Command:	type <i>M</i> and press Spacebar	<i>M</i> is the command alias for <i>Move</i>
2.	MOVE Select objects:	use pickbox to select one <i>Line</i> and the <i>Circle</i>	objects are highlighted
3.	Select objects:	press Spacebar or Enter	
4.	Specify base point or displacement:	PICK near the <i>Circle</i> center	base point is the handle, or where to move <i>from</i>
5.	Specify second point of displacement:	PICK near the other <i>Line</i>	second point is where to move <i>to</i>

2. Use *Move* again to move the *Circle* back to its original position. Select the *Circle* with the *Window* option.

STEPS	COMMAND PROMPT	PERFORM ACTION	COMMENTS
1.	Command:	select the <i>Modify</i> pull-down, then <i>Move</i>	
2.	MOVE Select objects:	type <i>W</i> and press Spacebar	select only the circle; object is highlighted
3.	Select objects:	press Spacebar or Enter	
4.	Specify base point or displacement:	PICK near the <i>Circle</i> center	base point is the handle, or where to move <i>from</i>
5.	Specify second point of displacement:	PICK near the original location	second point is where to move <i>to</i>

Practice Tables

Step-by-step practice exercises in the early chapters help you systematically tackle fundamental skills.

168 Modify Commands I

STRETCH



Pull-down Menu	COMMAND (TYPE)	ALIAS (TYPE)	Short-cut	Screen (side) Menu	Tablet Menu
Modify Stretch	STRETCH	S	...	MODIFY2 Stretch	V,22

Objects can be made longer or shorter with Stretch. The power of this command lies in the ability to Stretch groups of objects while retaining the connectivity of the group (Fig. 9-9). When Stretched, Lines and Plines become longer or shorter and Arcs change radius to become longer or shorter. Circles do not stretch; rather, they move if the center is selected within the Crossing Window.

Objects to Stretch are not selected by the typical object selection methods but are indicated by a Crossing Window or Crossing Polygon only. The Crossing Window or Polygon should be created so the objects to Stretch cross through the window. Stretch actually moves the object endpoints that are located within the Crossing Window.

Following is the command sequence for Stretch.

- Command: **stretch**
- Select objects to stretch by crossing-window or crossing-polygon...
- Select objects: **PICK**
- Specify opposite corner: **PICK**
- Select objects: **Enter**
- Specify base point or displacement: **PICK** or (coordinates) (Select a point to stretch from.)
- Specify second point of displacement: **PICK** or (coordinates) (Select a point to stretch to.)
- Command:



Stretch can be used to lengthen one object while shortening another. Application of this ability would be repositioning a door or window on a wall (Fig. 9-10).

In summary, the Stretch command stretches objects that cross the selection Window and moves objects that are completely within the selection Window, as shown in Figure 9-10.

Figure 9-9

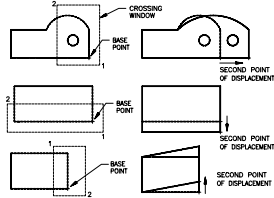
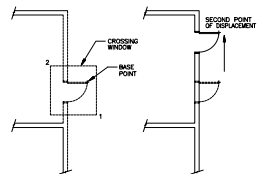

Figure 9-10



Command Tables

Whenever an AutoCAD command is introduced in the book, this table indicates all the methods you can use to call up the command.

“2004” and “2002” Bars

These vertical bars in the page margins allow you to quickly identify the commands and options that are new in AutoCAD 2004 and in AutoCAD 2002. This feature is especially helpful for readers updating from either AutoCAD 2002 or 2000.

914 3D Display and Viewing

Next, if you desire all views to display the object proportionally, use Zoom with a constant scale factor (such as 1, not 1x) in each viewport. This action would generate a display similar to that shown in Figure 35-38.

This 3D Setup option is available only from the Viewports dialog box. If you use one of the other options from the View pull-down menu (3 Viewports, 4 Viewports, etc.) or type the command line version (Vports), you cannot automatically generate a typical orthographic view setup.



NOTE: The setting of UCSORTHO has an effect on the resulting UCSs when the 3D Setup option of the Viewport dialog box is used. If UCSORTHO is set to 0, no new UCSs are created when Vports is used. However, if UCSORTHO is set to 1, a new UCS is generated for each new orthographic view created so that the XY plane of each new UCS is parallel with the view. In other words, each orthographic view (not the isometric) now shows a UCS with the XY plane parallel to the screen. See Chapter 36 for more information on the UCSORTHO system variable.

Figure 35-42

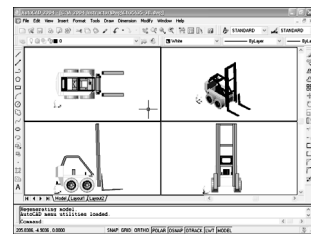

Printing Shaded 3D Models

In AutoCAD 2004 you can print 3D models in shaded mode. If you have a laserjet, inkjet, or electrostatic type printer configured as the plot device (not a pen plotter), you can select from As Displayed, Wireframe, Hidden, or Rendered options from the Plot dialog box or from the Properties palette for the viewport.

Printing a Shaded Image From the Model Tab

If you want to print a shaded 3D drawing from the Model tab, use the Shaded Viewport Options section of the Plot dialog box, Plot Settings tab. Use the Shade Plot drop-down list to produce the desired Wireframe, Hidden, or Rendered display in the print (Fig. 35-43). Alternately, you can use the Shademode or Render commands to produce the desired display on screen, then select As Displayed from this list to print the drawing as it appears on screen. You can also select from several resolution qualities for the print (see the “Shaded Viewport Options” section in Chapter 14).

Printing a Shaded Image From a Layout Tab

If you are printing from a layout and want to specify a shaded image for one or more viewports, use the Shadeplot option of the viewport’s Properties palette. Here you can select from the same options (Fig. 35-44) as in the Plot dialog box.

Figure 35-43

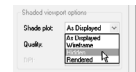
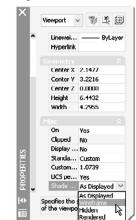

Figure 35-44



2004

“TIP!” Icons

“TIP!” icons point out time-saving tricks and tips that otherwise might be discovered only after much experience with AutoCAD.

342 Draw Commands II

Editing Multilines

Because a multiline is treated as one object and its complex configuration is defined by the multiline style, traditional editing commands such as *Trim* and *Extend*, cannot be used for typical editing functions. Instead, a special set of editing functions are designed for *Mlines*. The *Mledit* (multiline edit) command provides the editing functions for existing multilines and is discussed in Chapter 16. Your use for *Mlines* is limited until you can edit them with *Mledit*.

SKETCH

Pull-down Menu	COMMAND (TYPE)	ALIAS (TYPE)	Short-cut	Screen (side) Menu	Tablet Menu
...	SKETCH

The *Sketch* command is unlike other draw commands. *Sketch* quickly creates many short line segments (individual objects) by following the motions of the cursor. *Sketch* is used to give the appearance of a freehand “sketched” line, as used in Figure 15-32 for the tree and bushes. You do not specify individual endpoints, but rather draw a freehand line by placing the pen down, moving the cursor, and then picking up the pen. This action creates a large number of short *Line* segments. *Sketch* line segments are temporary (displayed in a different color) until *Recorded* or until *Exiting Sketch*.

Figure 15-32



CAUTION: *Sketch* can increase the drawing file size greatly due to the relatively large number of line segment endpoints required to define the *Sketch* line.

Command: *sketch*
 Record increment <0.1000> (value) or Enter (Enter a value to specify the segment increment length or press Enter to accept the default increment.)
 Sketch. Pen eXit Quit Record Erase Connect. (Letter) (Enter “p” or press button #1 to put the pen down and begin drawing or enter another letter for another option. After drawing a sketch line, enter “p” or press button #1 again to pick up the pen.)

It is important to specify an *increment* length for the short line segments that are created. This *increment* controls the “resolution” of the *Sketch* line (Fig. 15-33).

Figure 15-33

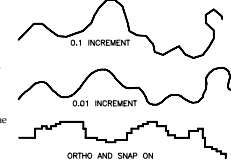

TIP! Too large of an *increment* makes the straight line segments apparent, while too small of an *increment* unnecessarily increases file size. The default *increment* is 0.1 (appropriate for default *Limits* of 12 x 9) and should be changed proportionally with a change in *Limits*. Generally, multiply the default *increment* of 0.1 times the drawing scale factor.

746 References

Overlay

An *Xref Overlay* is similar to an *Attached Xref* with one main difference—an *Overlay* cannot be nested. In other words, if you *Attach* a drawing that (itself) has an *Overlay*, the *Overlay* does not appear in your drawing. On the other hand, if the first drawing is *Attached*, it appears when the parent drawing is *Attached* to another drawing (Fig. 30-18).

Figure 30-18

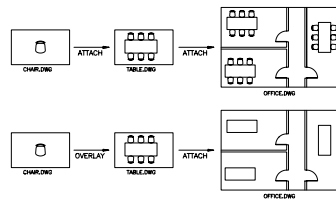

To produce an *Overlay* using the *Xref Manager*, you must first select the *Attach* button to produce the *Select File* dialog box. After selecting the desired file to overlay, press the *Overlay* button in the *External Reference* dialog box that appears (Fig. 30-19). If you type the *-Xref* command, simply use the *Overlay* option and the standard *Select File* dialog box appears.

Figure 30-19



The *Overlay* option prevents “circular” *Xrefs* from appearing by preventing unwanted nested *Xrefs*. This is helpful in a networking environment where many drawings *Xref* other drawings. For example, assume drawing B has drawing A as an *Overlay*. As you work on drawing C, you *Xref* and view only drawing B without drawing B’s overlays—namely drawing A. This occurs because drawing A is an *Overlay* to B, not *Attached*. If all drawings are *Overlays*, no nesting occurs (Fig. 30-20).

Figure 30-20

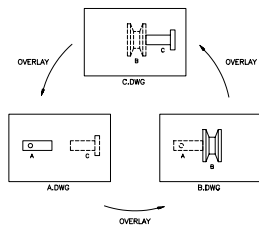

Graphically Driven Page Layout

Over 1500 illustrations are given in the book. Explanatory text is located directly next to the related figure.

Chapter Twenty-Four 581

CHAPTER EXERCISES

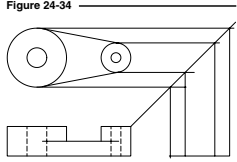
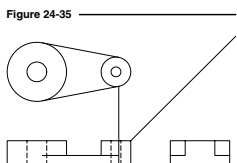
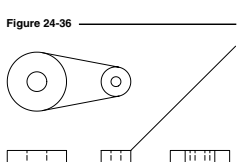
- Open the PIVOTARM CH16 drawing.
 - Create the right side view. Use **OSNAP** and **ORTHO** or **Polar Tracking** to create **Lines** or **Rays** to the miter line and down to the right side view as shown in Figure 24-34. **Offset** may be used effectively for this purpose instead. Use **Extend**, **Offset**, or **Ray** to create the projection lines from the front view to the right side view. Use **Object Snap Tracking** when appropriate.
 
 - Trim** or **Erase** the unwanted projection lines, as shown in Figure 24-35. Draw a **Line** or **Ray** from the **Endpoint** of the diagonal **Line** in the top view down to the front to supply the boundary edge for **Trimming** the horizontal **Line** in the front view as shown.
 
 - Next, create the hidden lines for the holes by the same fashion as before. Use previously created **Layers** to achieve the desired **Linetypes**. Complete the side view by adding the horizontal hidden **Line** in the center of the view.
 

Chapter Exercises

Exercises help you try out the commands discussed in each chapter. Exercises begin with simple, step-by-step use of commands and progress to more advanced drawings based on synthesis of earlier ideas.

Reference Material

Useful for self study or classroom use, tabbed pages help you quickly locate the Command Table Index, Shortcut Keys, Dimension Variables, System Variables, Tables of Limits Settings, Template Drawings and more.

1260 Command Table Index

Command Name (type)	Button	Pull-down Menu	ALIAS (type)	Short Cut	Screen (side) Menu	Tablet Menu	Chapter in this Text
HELP		Help Help	?	F1	HELP Help	Y,7	5
HIDE		View Hide	HI	...	VIEW2 Hide	M,2	35
HLSSETTINGS	35
HYPERLINK		Insert Hyperlink...	...	Ctrl+K	19
HYPERLINKBASE	19
ID		Tools Inquiring > ID Point	TOOLS1 ID	U,9	17
IMAGE -IMAGE		Insert Image Manager...	IM, -IM	...	INSERT Image	T,3	32
IMAGEADJUST		Modify Object> Image Adjust...	IAD	...	MODIFY1 Imageadj	X,20	32
IMAGEATTACH		Insert Image Manager> Attach...	IAT	...	INSERT Image Attach...	...	32
IMAGECLIP		Modify Object> Image Clip	ICL	...	MODIFY1 Imageclip	X,22	32
IMAGEFRAME		Modify Object> Image Frame	MODIFY1 Imagefrm	...	32
IMAGEQUALITY		Modify Object> Image Quality	MODIFY1 Imagequa	...	32
IMPORT		...	IMP	T,2	32
INDEXCTL		File Services... Tools Options... Index type	FILE Services... Options... Index type	...	30
INLOCATION		Tools Options Files Misc, File Names Default internet Location	TOOLS2 Files Misc, Help, and Misc, File Names Default internet Location	...	19
INSERT -INSERT		Insert Block...	I, -I	...	INSERT Dinsert	T,5	21
INSERTOBJ		Insert OLE Object...	IO	...	INSERT Insertobj	T,1	31
INTERFERE		Draw Solids > Interference	INF	...	DRAW2 SOLIDS Interfer	...	39

Supplements at www.mhhe.com/leach

An online learning center provides additional material for students and instructors. Students can download 25 test or review questions for each chapter, discipline-specific exercises for each chapter (architectural, mechanical and civil/electrical), and even 3 additional advanced chapters. Solutions for the chapter exercises (.DWG files) and review questions (Word format) are available for instructors.

