

C H A P T E R

4

AC NETWORK ANALYSIS

Chapter 4 is dedicated to two main ideas: *energy storage (dynamic) circuit elements* and the analysis of *AC circuits excited by sinusoidal voltages and currents*. First, dynamic circuit elements, that is, capacitors and inductors, are defined. These are circuit elements that are described by an *i-v* characteristic of differential or integral form. Next, *time-dependent signal sources* and the concepts of average and root-mean-square (rms) values are introduced. Special emphasis is placed on sinusoidal signals, as this class of signals is especially important in the analysis of electric circuits (think, e.g., of the fact that all electric power for residential and industrial uses comes in sinusoidal form). Once these basic elements have been presented, the focus shifts to how to write circuit equations when time-dependent sources and dynamic elements are present. The equations that result from the application of KVL and KCL take the form of differential equations. The general solution of these differential equations is covered in Chapter 5. The remainder of the chapter discusses one particular case: the solution of circuit differential equations when the excitation is a sinusoidal voltage or current; a very powerful method, *phasor analysis*, is introduced along with the related concept of *impedance*. This methodology effectively converts the circuit differential equations to algebraic equations in which complex algebra notation is used to arrive at the solution. Phasor analysis is then used to



Fluid (Hydraulic) Capacitance

We continue the analogy between electrical and hydraulic circuits. If a vessel has some elasticity, energy is stored in the expansion and contraction of the vessel walls (this should remind you of a mechanical spring). This phenomenon gives rise to a **fluid capacitance** effect very similar to electrical capacitance. The energy stored in the compression and expansion of the gas is of the *potential energy* type. Figure 4.1 depicts a gas-bag accumulator: a two-chamber arrangement that permits fluid to displace a membrane separating the incompressible fluid from a compressible fluid (e.g., air). The analogy shown in Figure 4.1 assumes that the reference pressure p_0 is zero (“ground” or reference pressure), and that v_2 is ground. The analog equations are given below.

$$q_f = C_f \frac{d\Delta p}{dt} = C_f \frac{dp}{dt}$$

$$i = C \frac{d\Delta v}{dt} = C \frac{dv_1}{dt}$$

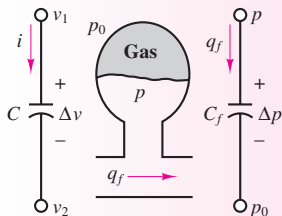

Figure 4.1 Analogy between electrical and fluid capacitance

demonstrate that all the network analysis techniques of Chapter 3 are applicable to the analysis of dynamic circuits with sinusoidal excitations, and a number of examples are presented.

Learning Objectives

1. Compute currents, voltages, and energy stored in capacitors and inductors. *Section 1.*
2. Calculate the average and root-mean-square value of an arbitrary (periodic) signal. *Section 2.*
3. Write the differential equation(s) for circuits containing inductors and capacitors. *Section 3.*
4. Convert time-domain sinusoidal voltages and currents to phasor notation, and vice versa, and represent circuits using impedances. *Section 4.*

4.1 ENERGY STORAGE (DYNAMIC) CIRCUIT ELEMENTS

The ideal resistor was introduced through Ohm’s law in Chapter 2 as a useful idealization of many practical electrical devices. However, in addition to resistance to the flow of electric current, which is purely a dissipative (i.e., an energy loss) phenomenon, electric devices may exhibit energy storage properties, much in the same way as a spring or a flywheel can store mechanical energy. Two distinct mechanisms for energy storage exist in electric circuits: **capacitance** and **inductance**, both of which lead to the storage of energy in an electromagnetic field. For the purpose of this discussion, it will not be necessary to enter into a detailed electromagnetic analysis of these devices. Rather, two ideal circuit elements will be introduced to represent the ideal properties of capacitive and inductive energy storage: the **ideal capacitor** and the **ideal inductor**. It should be stated clearly that ideal capacitors and inductors do not exist, strictly speaking; however, just like the ideal resistor, these “ideal” elements are very useful for understanding the behavior of physical circuits. In practice, any component of an electric circuit will exhibit some resistance, some inductance, and some capacitance—that is, some energy dissipation and some energy storage. The sidebar on hydraulic analogs of electric circuits illustrates that the concept of capacitance does not just apply to electric circuits.

The Ideal Capacitor

A physical capacitor is a device that can store energy in the form of a charge separation when appropriately polarized by an electric field (i.e., a voltage). The simplest capacitor configuration consists of two parallel conducting plates of cross-sectional area A , separated by air (or another **dielectric**¹ material, such as mica or Teflon). Figure 4.2 depicts a typical configuration and the circuit symbol for a capacitor.

¹A dielectric material is a material that is not an electrical conductor but contains a large number of electric dipoles, which become polarized in the presence of an electric field.

The presence of an insulating material between the conducting plates does not allow for the flow of DC current; thus, a capacitor acts as an open circuit in the presence of DC current. However, if the voltage present at the capacitor terminals changes as a function of time, so will the charge that has accumulated at the two capacitor plates, since the degree of polarization is a function of the applied electric field, which is time-varying. In a capacitor, the charge separation caused by the polarization of the dielectric is proportional to the external voltage, that is, to the applied electric field

$$Q = CV \tag{4.1}$$

where the parameter C is called the *capacitance* of the element and is a measure of the ability of the device to accumulate, or store, charge. The unit of capacitance is coulomb per volt and is called the **farad (F)**. The farad is an unpractically large unit for many common electronic circuit applications; therefore it is common to use microfarads ($1 \mu\text{F} = 10^{-6} \text{ F}$) or picofarads ($1 \text{ pF} = 10^{-12} \text{ F}$). From equation 4.1 it becomes apparent that if the external voltage applied to the capacitor plates changes in time, so will the charge that is internally stored by the capacitor:

$$q(t) = Cv(t) \tag{4.2}$$

Thus, although no current can flow through a capacitor if the voltage across it is constant, a time-varying voltage will cause charge to vary in time.

The change with time in the stored charge is analogous to a current. You can easily see this by recalling the definition of current given in Chapter 2, where it was stated that

$$i(t) = \frac{dq(t)}{dt} \tag{4.3}$$

that is, electric current corresponds to the time rate of change of charge. Differentiating equation 4.2, one can obtain a relationship between the current and voltage in a capacitor:

$$i(t) = C \frac{dv(t)}{dt} \quad i\text{-}v \text{ relation for capacitor} \tag{4.4}$$

Equation 4.4 is the defining circuit law for a capacitor. If the differential equation that defines the i - v relationship for a capacitor is integrated, one can obtain the following relationship for the voltage across a capacitor:

$$v_C(t) = \frac{1}{C} \int_{-\infty}^t i_C(t') dt' \tag{4.5}$$

Equation 4.5 indicates that the capacitor voltage depends on the past current through the capacitor, up until the present time t . Of course, one does not usually have precise information regarding the flow of capacitor current for all past time, and so it is useful to define the initial voltage (or *initial condition*) for the capacitor according to the following, where t_0 is an arbitrary initial time:

$$V_0 = v_C(t = t_0) = \frac{1}{C} \int_{-\infty}^{t_0} i_C(t') dt' \tag{4.6}$$

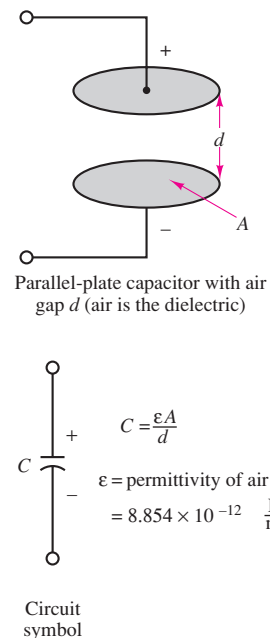

Figure 4.2 Structure of parallel-plate capacitor



The capacitor voltage is now given by the expression

$$v_C(t) = \frac{1}{C} \int_{t_0}^t i_C(t') dt' + V_0 \quad t \geq t_0 \quad (4.7)$$

The significance of the initial voltage V_0 is simply that at time t_0 some charge is stored in the capacitor, giving rise to a voltage $v_C(t_0)$, according to the relationship $Q = CV$. Knowledge of this initial condition is sufficient to account for the entire history of the capacitor current.

Capacitors connected in series and parallel can be combined to yield a single equivalent capacitance. The rule of thumb, which is illustrated in Figure 4.3, is the following:

Capacitors in parallel add. Capacitors in series combine according to the same rules used for resistors connected in parallel.

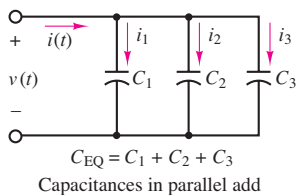
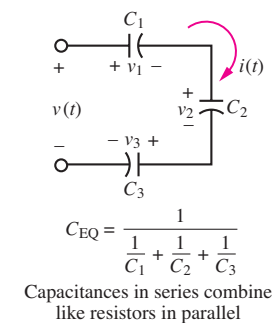

Figure 4.3 Combining capacitors in a circuit

It is very easy to prove that capacitors in series combine as shown in Figure 4.3, using the definition of equation 4.5. Consider the three capacitors in series in the circuit of Figure 4.3. Using Kirchhoff's voltage law and the definition of the capacitor voltage, we can write

$$\begin{aligned} v(t) &= v_1(t) + v_2(t) + v_3(t) \\ &= \frac{1}{C_1} \int_{-\infty}^t i(t') dt' + \frac{1}{C_2} \int_{-\infty}^t i(t') dt' + \frac{1}{C_3} \int_{-\infty}^t i(t') dt' \\ &= \left(\frac{1}{C_1} + \frac{1}{C_2} + \frac{1}{C_3} \right) \int_{-\infty}^t i(t') dt' \end{aligned} \quad (4.8)$$

Thus, the voltage across the three series capacitors is the same as would be seen across a single equivalent capacitor C_{eq} with $1/C_{eq} = 1/C_1 + 1/C_2 + 1/C_3$, as illustrated in Figure 4.3. You can easily use the same method to prove that the three parallel capacitors in the bottom half of Figure 4.3 combine as do resistors in series.



EXAMPLE 4.1 Charge Separation in Ultracapacitors

Problem



Ultracapacitors are finding application in a variety of fields, including as a replacement or supplement for batteries in hybrid-electric vehicles. In this example you will make your first acquaintance with these devices.

An ultracapacitor, or “supercapacitor,” stores energy electrostatically by polarizing an electrolytic solution. Although it is an electrochemical device (also known as an electrochemical double-layer capacitor), there are no chemical reactions involved in its energy storage mechanism. This mechanism is highly reversible, allowing the ultracapacitor to be charged and discharged hundreds of thousands of times. An ultracapacitor can be viewed as two nonreactive porous

plates suspended within an electrolyte, with a voltage applied across the plates. The applied potential on the positive plate attracts the negative ions in the electrolyte, while the potential on the negative plate attracts the positive ions. This effectively creates two layers of capacitive storage, one where the charges are separated at the positive plate and another at the negative plate.

Recall that capacitors store energy in the form of separated electric charge. The greater the area for storing charge and the closer the separated charges, the greater the capacitance. A conventional capacitor gets its area from plates of a flat, conductive material. To achieve high capacitance, this material can be wound in great lengths, and sometimes a texture is imprinted on it to increase its surface area. A conventional capacitor separates its charged plates with a dielectric material, sometimes a plastic or paper film, or a ceramic. These dielectrics can be made only as thin as the available films or applied materials.

An ultracapacitor gets its area from a porous carbon-based electrode material, as shown in Figure 4.4. The porous structure of this material allows its surface area to approach 2,000 square meters per gram (m^2/g), much greater than can be accomplished using flat or textured films and plates. An ultracapacitor's charge separation distance is determined by the size of the ions in the electrolyte, which are attracted to the charged electrode. This charge separation [less than 10 angstroms (\AA)] is much smaller than can be achieved using conventional dielectric materials. The combination of enormous surface area and extremely small charge separation gives the ultracapacitor its outstanding capacitance relative to conventional capacitors.

Use the data provided to calculate the charge stored in an ultracapacitor, and calculate how long it will take to discharge the capacitor at the maximum current rate.

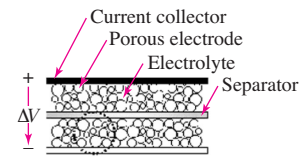

Figure 4.4 Ultracapacitor structure

Solution

Known Quantities: Technical specifications are as follows:

Capacitance	100 F	(−10% / + 30%)
Series resistance	DC	15 mΩ (±25%)
	1 kHz	7 mΩ (±25%)
Voltage	Continuous	2.5 V; Peak 2.7 V
Rated current	25 A	

Find: Charge separation at nominal voltage and time to complete discharge at maximum current rate.

Analysis: Based on the definition of charge storage in a capacitor, we calculate

$$Q = CV = 100 \text{ F} \times 2.5 \text{ V} = 250 \text{ C}$$

To calculate how long it would take to discharge the ultracapacitor, we approximate the defining differential equation (4.4) as follows:

$$i = \frac{dq}{dt} \approx \frac{\Delta q}{\Delta t}$$

Since we know that the discharge current is 25 A and the available charge separation is 250 C, we can calculate the time to complete discharge, assuming a constant 25-A discharge:

$$\Delta t = \frac{\Delta q}{i} = \frac{250 \text{ C}}{25 \text{ A}} = 10 \text{ s}$$

Comments: We shall continue our exploration of ultracapacitors in Chapter 5. In particular, we shall look more closely at the charging and discharging behavior of these devices, taking into consideration their internal resistance.

CHECK YOUR UNDERSTANDING

Compare the charge separation achieved in this ultracapacitor with a (similarly sized) electrolytic capacitor used in power electronics applications, by calculating the charge separation for a 2,000- μF electrolytic capacitor rated at 400 V.

Answer: 0.8 C



EXAMPLE 4.2 Calculating Capacitor Current from Voltage

Problem

Calculate the current through a capacitor from knowledge of its terminal voltage.

Solution

Known Quantities: Capacitor terminal voltage; capacitance value.

Find: Capacitor current.

Assumptions: The initial current through the capacitor is zero.

Schematics, Diagrams, Circuits, and Given Data: $v(t) = 5(1 - e^{-t/10^{-6}})$ volts; $t \geq 0$ s; $C = 0.1 \mu\text{F}$. The terminal voltage is plotted in Figure 4.5.

Assumptions: The capacitor is initially discharged: $v(t = 0) = 0$.

Analysis: Using the defining differential relationship for the capacitor, we may obtain the current by differentiating the voltage:

$$i_C(t) = C \frac{dv(t)}{dt} = 10^{-7} \frac{5}{10^{-6}} \left(e^{-t/10^{-6}} \right) = 0.5 e^{-t/10^{-6}} \quad \text{A} \quad t \geq 0$$

A plot of the capacitor current is shown in Figure 4.6. Note how the current jumps to 0.5 A instantaneously as the voltage rises exponentially: The ability of a capacitor's current to change instantaneously is an important property of capacitors.

Comments: As the voltage approaches the constant value 5 V, the capacitor reaches its maximum charge storage capability for that voltage (since $Q = CV$) and no more current flows through the capacitor. The total charge stored is $Q = 0.5 \times 10^{-6}$ C. This is a fairly small amount of charge, but it can produce a substantial amount of current for a brief time. For example, the fully charged capacitor could provide 100 mA of current for a time equal to 5 μs :

$$I = \frac{\Delta Q}{\Delta t} = \frac{0.5 \times 10^{-6}}{5 \times 10^{-6}} = 0.1 \text{ A}$$

There are many useful applications of this energy storage property of capacitors in practical circuits.

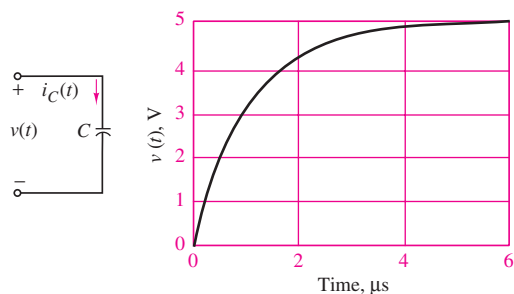

Figure 4.5

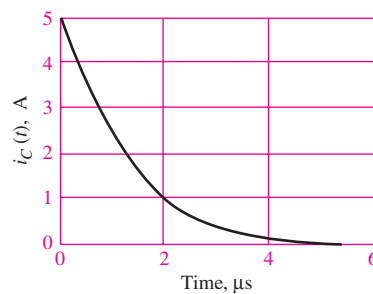
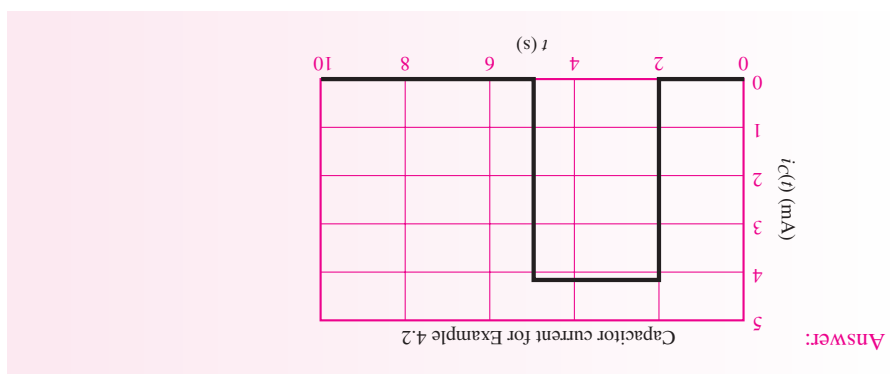
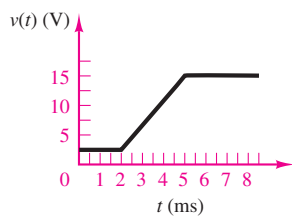

Figure 4.6

CHECK YOUR UNDERSTANDING

The voltage waveform shown below appears across a 1,000- μ F capacitor. Plot the capacitor current $i_C(t)$.



EXAMPLE 4.3 Calculating Capacitor Voltage from Current and Initial Conditions



Problem

Calculate the voltage across a capacitor from knowledge of its current and initial state of charge.

Solution**Known Quantities:** Capacitor current; initial capacitor voltage; capacitance value.**Find:** Capacitor voltage.**Schematics, Diagrams, Circuits, and Given Data:**

$$i_C(t) = I \begin{cases} 0 & t < 0 \text{ s} \\ 10 \text{ mA} & 0 \leq t \leq 1 \text{ s} \\ 0 & t > 1 \text{ s} \end{cases}$$

$$v_C(t = 0) = 2 \text{ V} \quad C = 1,000 \mu\text{F}$$

The capacitor current is plotted in Figure 4.7(a).

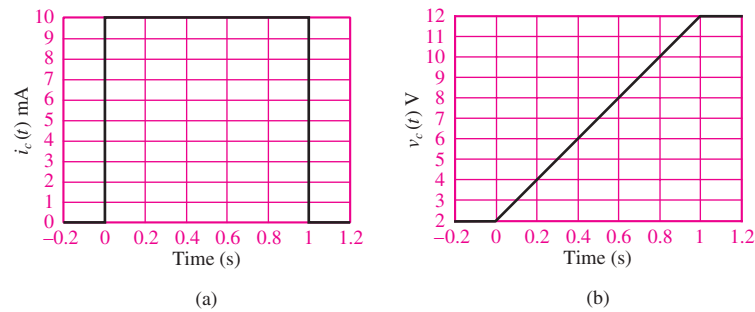
**Figure 4.7****Assumptions:** The capacitor is initially charged such that $v_C(t = t_0 = 0) = 2 \text{ V}$.**Analysis:** Using the defining integral relationship for the capacitor, we may obtain the voltage by integrating the current:

$$v_C(t) = \frac{1}{C} \int_{t_0}^t i_C(t') dt' + v_C(t_0) \quad t \geq t_0$$

$$= \begin{cases} \frac{1}{C} \int_0^1 I dt' + V_0 = \frac{I}{C} t + V_0 = 10t + 2 \text{ V} & 0 \leq t \leq 1 \text{ s} \\ 12 \text{ V} & t > 1 \text{ s} \end{cases}$$

Comments: Once the current stops, at $t = 1 \text{ s}$, the capacitor voltage cannot develop any further but remains at the maximum value it reached at $t = 1 \text{ s}$: $v_C(t = 1) = 12 \text{ V}$. The final value of the capacitor voltage after the current source has stopped charging the capacitor depends on two factors: (1) the initial value of the capacitor voltage and (2) the history of the capacitor current. Figure 4.7(a) and (b) depict the two waveforms.**CHECK YOUR UNDERSTANDING**Find the maximum current through the capacitor of Example 4.3 if the capacitor voltage is described by $v_C(t) = 5t + 3 \text{ V}$ for $0 \leq t \leq 5 \text{ s}$.

Answer: 5 mA

Physical capacitors are rarely constructed of two parallel plates separated by air, because this configuration yields very low values of capacitance, unless one is willing to tolerate very large plate areas. To increase the capacitance (i.e., the ability to store energy), physical capacitors are often made of tightly rolled sheets of metal film, with a dielectric (paper or Mylar) sandwiched in between. Table 4.1 illustrates typical values, materials, maximum voltage ratings, and useful frequency ranges for various types of capacitors. The voltage rating is particularly important, because any insulator will break down if a sufficiently high voltage is applied across it.



Table 4.1 Capacitors

Material	Capacitance range	Maximum voltage (V)	Frequency range (Hz)
Mica	1 pF to 0.1 μ F	100–600	10^3 – 10^{10}
Ceramic	10 pF to 1 μ F	50–1,000	10^3 – 10^{10}
Mylar	0.001 μ F to 10 μ F	50–500	10^2 – 10^8
Paper	1,000 pF to 50 μ F	100–105	10^2 – 10^8
Electrolytic	0.1 μ F to 0.2 F	3–600	10 – 10^4

Energy Storage in Capacitors

You may recall that the capacitor was described earlier in this section as an energy storage element. An expression for the energy stored in the capacitor $W_C(t)$ may be derived easily if we recall that energy is the integral of power, and that the instantaneous power in a circuit element is equal to the product of voltage and current:

$$\begin{aligned}
 W_C(t) &= \int P_C(t') dt' \\
 &= \int v_C(t') i_C(t') dt' \\
 &= \int v_C(t') C \frac{dv_C(t')}{dt'} dt'
 \end{aligned} \tag{4.9}$$

$$W_C(t) = \frac{1}{2} C v_C^2(t) \quad \text{Energy stored in a capacitor (J)}$$



Example 4.4 illustrates the calculation of the energy stored in a capacitor.

EXAMPLE 4.4 Energy Storage in Ultracapacitors

Problem

Determine the energy stored in the ultracapacitor of Example 4.1.

Solution**Known Quantities:** See Example 4.1.**Find:** Energy stored in capacitor.**Analysis:** To calculate the energy, we use equation 4.9:

$$W_C = \frac{1}{2} C v_C^2 = \frac{1}{2} (100 \text{ F})(2.5 \text{ V})^2 = 312.5 \text{ J}$$

CHECK YOUR UNDERSTANDING

Compare the energy stored in this ultracapacitor with a (similarly sized) electrolytic capacitor used in power electronics applications, by calculating the charge separation for a 2,000- μF electrolytic capacitor rated at 400 V.

Answer: 160 J

The Ideal Inductor

The ideal inductor is an element that has the ability to store energy in a magnetic field. Inductors are typically made by winding a coil of wire around a **core**, which can be an insulator or a ferromagnetic material, as shown in Figure 4.8. When a current flows through the coil, a magnetic field is established, as you may recall from early physics experiments with electromagnets. Just as we found an analogy between electric and fluid circuits for the capacitor, we can describe a phenomenon similar to inductance in hydraulic circuits, as explained in the sidebar. In an ideal inductor, the resistance of the wire is zero so that a constant current through the inductor will flow freely without causing a voltage drop. In other words, *the ideal inductor acts as a short circuit in the presence of DC*. If a time-varying voltage is established across the inductor, a corresponding current will result, according to the following relationship:



$$v_L(t) = L \frac{di_L(t)}{dt} \quad i\text{-}v \text{ relation for inductor} \quad (4.10)$$

where L is called the *inductance* of the coil and is measured in **henrys (H)**, where

$$1 \text{ H} = 1 \text{ V}\cdot\text{s}/\text{A} \quad (4.11)$$

Henrys are reasonable units for **practical inductors**; millihenrys (mH) and microhenrys (μH) are also used.

It is instructive to compare equation 4.10, which defines the behavior of an ideal inductor, with the expression relating capacitor current and voltage:

$$i_C(t) = C \frac{dv_C(t)}{dt} \quad (4.12)$$



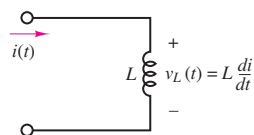

(a) Circuit symbol

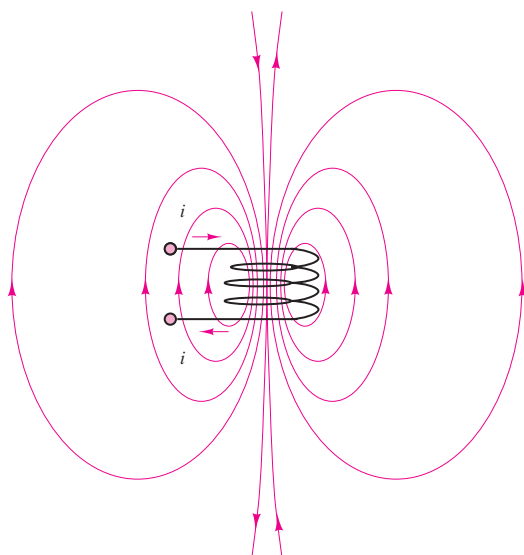

(b) Magnetic flux lines in the vicinity of a current-carrying coil

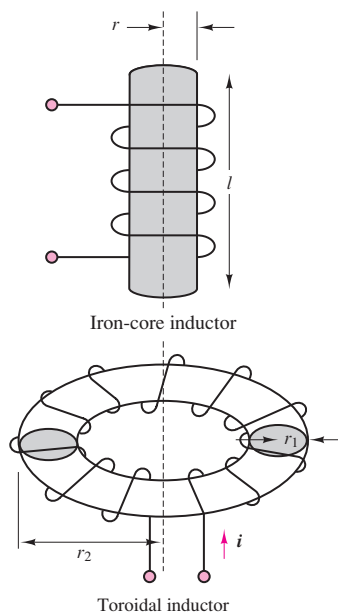

(c) Practical inductors

Figure 4.8 Inductance and practical inductors

We note that the roles of voltage and current are reversed in the two elements, but that both are described by a differential equation of the same form. This *duality* between inductors and capacitors can be exploited to derive the same basic results for the inductor that we already have for the capacitor, simply by replacing the capacitance parameter C with the inductance L and voltage with current (and vice versa) in

Table 4.2 Analogy between electric and fluid circuits

Property	Electrical element or equation	Hydraulic analogy
Potential variable	Voltage or potential difference	Pressure difference
Flow variable	Current flow	Fluid volume flow rate
Resistance	Resistor R	Fluid resistor R_f
Capacitance	Capacitor C	Fluid capacitor C_f
Inductance	Inductor L	Fluid inductor I_f
Power dissipation	$P = i^2 R$	$P_f = q_f^2 R_f$
Potential energy storage	$W_p = \frac{1}{2} C v^2$	$W_p = \frac{1}{2} C_f p^2$
Kinetic energy storage	$W_k = \frac{1}{2} L i^2$	$W_k = \frac{1}{2} I_f q_f^2$



Fluid (Hydraulic) Inertance

The **fluid inertance** parameter is analogous to inductance in the electric circuit. Fluid inertance, as the name suggests, is caused by the inertial properties, i.e., the mass, of the fluid in motion. As you know from physics, a particle in motion has kinetic energy associated with it; fluid in motion consists of a collection of particles, and it also therefore must have kinetic energy storage properties. (Think of water flowing out of a fire hose!) The equations that define the analogy are given below

$$\Delta p = p_1 - p_2 = I_f \frac{dq_f}{dt}$$

$$\Delta v = v_1 - v_2 = L \frac{di}{dt}$$

Figure 4.9 depicts the analogy between electrical inductance and fluid inertance. These analogies and the energy equations that apply to electrical and fluid circuit elements are summarized in Table 4.2.

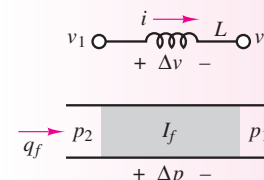

Figure 4.9 Analogy between fluid inertance and electrical inductance

the equations we derived for the capacitor. Thus, the inductor current is found by integrating the voltage across the inductor:

$$i_L(t) = \frac{1}{L} \int_{-\infty}^t v_L(t') dt' \quad (4.13)$$

If the current flowing through the inductor at time $t = t_0$ is known to be I_0 , with

$$I_0 = i_L(t = t_0) = \frac{1}{L} \int_{-\infty}^{t_0} v_L(t') dt' \quad (4.14)$$

then the inductor current can be found according to the equation

$$i_L(t) = \frac{1}{L} \int_{t_0}^t v_L(t') dt' + I_0 \quad t \geq t_0 \quad (4.15)$$

Series and parallel combinations of inductors behave as resistors, as illustrated in Figure 4.10, and stated as follows:



Inductors in series add. Inductors in parallel combine according to the same rules used for resistors connected in parallel.

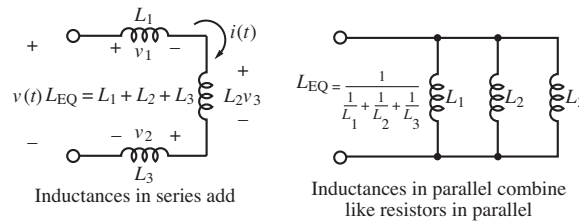

Figure 4.10 Combining inductors in a circuit

It is very easy to prove that inductors in series combine as shown in Figure 4.10, using the definition of equation 4.10. Consider the three inductors in series in the circuit on the left of Figure 4.10. Using Kirchhoff's voltage law and the definition of the capacitor voltage, we can write

$$\begin{aligned} v(t) &= v_1(t) + v_1(t) + v_1(t) = L_1 \frac{di(t)}{dt} + L_2 \frac{di(t)}{dt} + L_3 \frac{di(t)}{dt} \\ &= (L_1 + L_2 + L_3) \frac{di(t)}{dt} \end{aligned} \quad (4.16)$$

Thus, the voltage across the three series inductors is the same that would be seen across a single equivalent inductor L_{eq} with $L_{eq} = L_1 + L_2 + L_3$, as illustrated in Figure 4.10. You can easily use the same method to prove that the three parallel inductors on the right half of Figure 4.10 combine as resistors in parallel do.



EXAMPLE 4.5 Calculating Inductor Voltage from Current

Problem

Calculate the voltage across the inductor from knowledge of its current.

Solution

Known Quantities: Inductor current; inductance value.

Find: Inductor voltage.

Schematics, Diagrams, Circuits, and Given Data:

$$i_L(t) = \begin{cases} 0 \text{ mA} & t < 1 \text{ ms} \\ -\frac{0.1}{4} + \frac{0.1}{4}t \text{ mA} & 1 \leq t \leq 5 \text{ ms} \\ 0.1 \text{ mA} & 5 \leq t \leq 9 \text{ ms} \\ 13 \times \frac{0.1}{4} - \frac{0.1}{4}t \text{ mA} & 9 \leq t \leq 13 \text{ ms} \\ 0 \text{ mA} & t > 13 \text{ ms} \end{cases}$$

$L = 10 \text{ H}$

The inductor current is plotted in Figure 4.11.

Assumptions: $i_L(t = 0) \leq 0$.

Analysis: Using the defining differential relationship for the inductor, we may obtain the voltage by differentiating the current:

$$v_L(t) = L \frac{di_L(t)}{dt}$$

Piecewise differentiating the expression for the inductor current, we obtain

$$v_L(t) = \begin{cases} 0 \text{ V} & t < 1 \text{ ms} \\ 0.25 \text{ V} & 1 < t \leq 5 \text{ ms} \\ 0 \text{ V} & 5 < t \leq 9 \text{ ms} \\ -0.25 \text{ V} & 9 < t \leq 13 \text{ ms} \\ 0 \text{ V} & t > 13 \text{ ms} \end{cases}$$

The inductor voltage is plotted in Figure 4.12.

Comments: Note how the inductor voltage has the ability to change instantaneously!

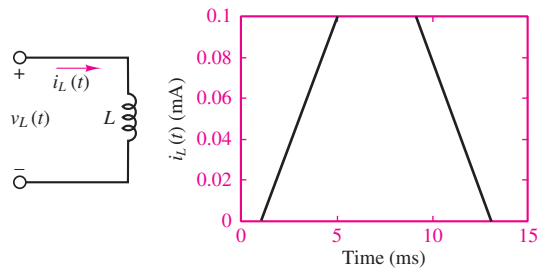

Figure 4.11

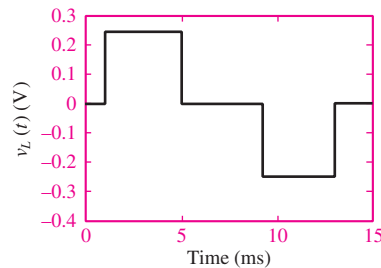
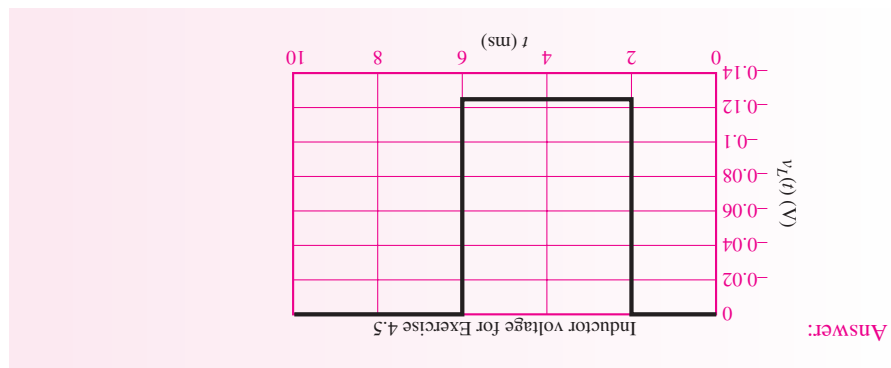
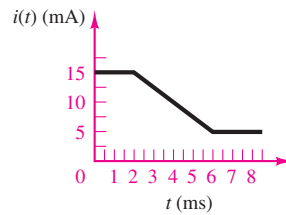

Figure 4.12

CHECK YOUR UNDERSTANDING

The current waveform shown below flows through a 50-mH inductor. Plot the inductor voltage $v_L(t)$.



EXAMPLE 4.6 Calculating Inductor Current from Voltage

Problem

Calculate the current through the inductor from knowledge of the terminal voltage and of the initial current.

Solution

Known Quantities: Inductor voltage; initial condition (current at $t = 0$); inductance value.

Find: Inductor current.

Schematics, Diagrams, Circuits, and Given Data:

$$v(t) = \begin{cases} 0 \text{ V} & t < 0 \text{ s} \\ -10 \text{ mV} & 0 < t \leq 1 \text{ s} \\ 0 \text{ V} & t > 1 \text{ s} \end{cases}$$

$$L = 10 \text{ mH}; \quad i_L(t = 0) = I_0 = 0 \text{ A}$$

The terminal voltage is plotted in Figure 4.13(a).

Assumptions: $i_L(t = 0) = I_0 = 0$.

Analysis: Using the defining integral relationship for the inductor, we may obtain the voltage

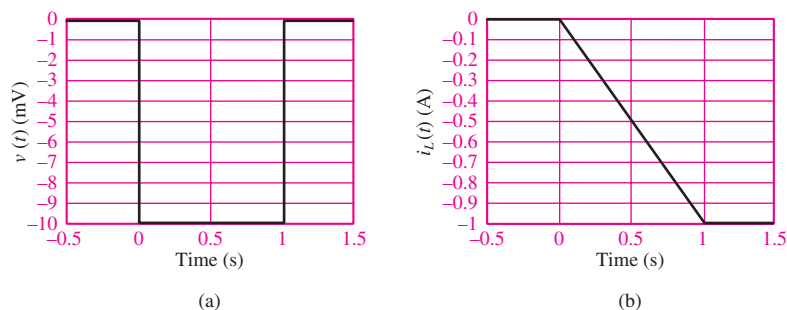
Figure 4.13

by integrating the current:

$$i_L(t) = \frac{1}{L} \int_{t_0}^t v(t') dt' + i_L(t_0) \quad t \geq t_0$$

$$= \begin{cases} \frac{1}{L} \int_0^t (-10 \times 10^{-3}) dt' + I_0 = \frac{-10^{-2}}{10^{-2}} t + 0 = -t \text{ A} & 0 \leq t \leq 1 \text{ s} \\ -1 \text{ A} & t > 1 \text{ s} \end{cases}$$

The inductor current is plotted in Figure 4.13(b).

Comments: Note how the inductor voltage has the ability to change instantaneously!

CHECK YOUR UNDERSTANDING

Find the maximum voltage across the inductor of Example 4.6 if the inductor current voltage is described by $i_L(t) = 2t$ amperes for $0 \leq t \leq 2$ s.

Answer: 20 mV

Energy Storage in Inductors

The magnetic energy stored in an ideal inductor may be found from a power calculation by following the same procedure employed for the ideal capacitor. The instantaneous power in the inductor is given by

$$P_L(t) = i_L(t)v_L(t) = i_L(t)L \frac{di_L(t)}{dt} = \frac{d}{dt} \left[\frac{1}{2} Li_L^2(t) \right] \quad (4.17)$$

Integrating the power, we obtain the total energy stored in the inductor, as shown in the following equation:

$$W_L(t) = \int P_L(t') dt' = \int \frac{d}{dt'} \left[\frac{1}{2} Li_L^2(t') \right] dt' \quad (4.18)$$



$$W_L(t) = \frac{1}{2} Li_L^2(t) \quad \text{Energy stored in an inductor (J)}$$

Note, once again, the duality with the expression for the energy stored in a capacitor, in equation 4.9.



EXAMPLE 4.7 Energy Storage in an Ignition Coil

Problem

Determine the energy stored in an automotive ignition coil.

Solution

Known Quantities: Inductor current initial condition (current at $t = 0$); inductance value.

Find: Energy stored in inductor.

Schematics, Diagrams, Circuits, and Given Data: $L = 10 \text{ mH}$; $i_L = I_0 = 8 \text{ A}$.

Analysis:

$$W_L = \frac{1}{2} Li_L^2 = \frac{1}{2} \times 10^{-2} \times 64 = 32 \times 10^{-2} = 320 \text{ mJ}$$

Comments: A more detailed analysis of an automotive ignition coil is presented in Chapter 5 to accompany the discussion of transient voltages and currents.

CHECK YOUR UNDERSTANDING

Calculate and plot the inductor energy and power for a 50-mH inductor subject to the current waveform shown below. What is the energy stored at $t = 3 \text{ ms}$? Assume $i(-\infty) = 0$.

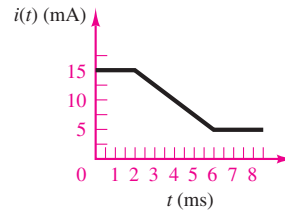

Answer: $5.625 \times 10^{-6} \text{ J}$

$$i(t) = \begin{cases} 0.156t^2 - (2.5 \times 10^{-3})t + 10^{-5} & 2 \leq t < 6 \text{ ms} \\ 0.625 \times 10^{-6} & t \geq 6 \text{ ms} \end{cases}$$

$$p(t) = \begin{cases} (20 \times 10^{-3} - 2.5t)(-0.125 \text{ W}) & 2 \leq t < 6 \text{ ms} \\ 0 & \text{otherwise} \end{cases}$$

$W = 5.625 \times 10^{-6} \text{ J}$

4.2 TIME-DEPENDENT SIGNAL SOURCES

In Chapter 2, the general concept of an ideal energy source was introduced. In this chapter, it will be useful to specifically consider sources that generate time-varying voltages and currents and, in particular, sinusoidal sources. Figure 4.14 illustrates the convention that will be employed to denote time-dependent signal sources.

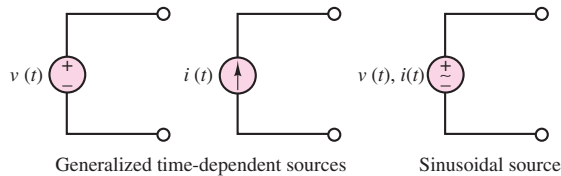

Figure 4.14 Time-dependent signal sources

One of the most important classes of time-dependent signals is that of **periodic signals**. These signals appear frequently in practical applications and are a useful approximation of many physical phenomena. A periodic signal $x(t)$ is a signal that satisfies the equation

$$x(t) = x(t + nT) \quad n = 1, 2, 3, \dots \tag{4.19}$$

where T is the **period** of $x(t)$. Figure 4.15 illustrates a number of periodic waveforms that are typically encountered in the study of electric circuits. Waveforms such as the sine, triangle, square, pulse, and sawtooth waves are provided in the form of voltages (or, less frequently, currents) by commercially available **signal** (or **waveform**) **generators**. Such instruments allow for selection of the waveform peak amplitude, and of its period.

As stated in the introduction, sinusoidal waveforms constitute by far the most important class of time-dependent signals. Figure 4.16 depicts the relevant parameters of a sinusoidal waveform. A generalized sinusoid is defined as

$$x(t) = A \cos(\omega t + \phi) \tag{4.20}$$

where A is the **amplitude**, ω the **radian frequency**, and ϕ the **phase**. Figure 4.16 summarizes the definitions of A , ω , and ϕ for the waveforms

$$x_1(t) = A \cos(\omega t) \quad \text{and} \quad x_2(t) = A \cos(\omega t + \phi)$$

where

$$\begin{aligned} f &= \text{natural frequency} = \frac{1}{T} && \text{cycles/s, or Hz} \\ \omega &= \text{radian frequency} = 2\pi f && \text{rad/s} \\ \phi &= 2\pi \frac{\Delta t}{T} && \text{rad} \\ &= 360 \frac{\Delta t}{T} && \text{deg} \end{aligned} \tag{4.21}$$

The phase shift ϕ permits the representation of an arbitrary sinusoidal signal. Thus, the choice of the reference cosine function to represent sinusoidal signals—arbitrary as it may appear at first—does not restrict the ability to represent all sinusoids. For example,

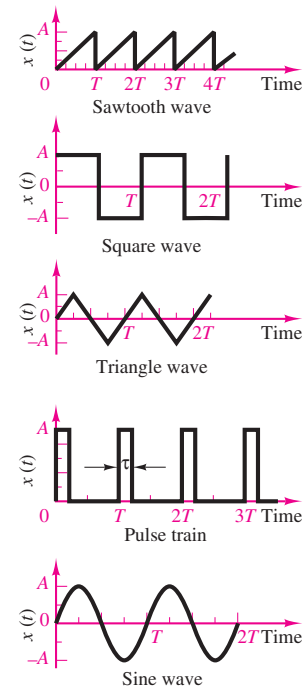

Figure 4.15 Periodic signal waveforms

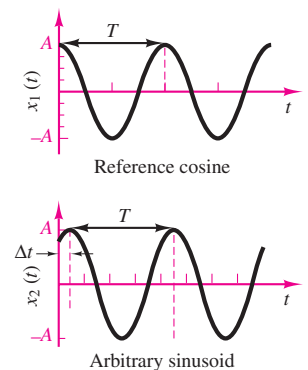

Figure 4.16 Sinusoidal waveforms



Why Do We Use Units of Radians for the Phase Angle ϕ ?

The engineer finds it frequently more intuitive to refer to the phase angle in units of degrees; however, to use consistent units in the argument (the quantity in the parentheses) of the expression $x(t) = A \sin(\omega t + \phi)$, we must express ϕ in units of radians, since the units of ωt are $[\omega] \cdot [t] = (\text{rad/s}) \cdot \text{s} = \text{rad}$. Thus, we will consistently use units of radians for the phase angle ϕ in all expressions of the form $x(t) = A \sin(\omega t + \phi)$. To be consistent is especially important when one is performing numerical calculations; if one used units of degrees for ϕ in calculating the value of $x(t) = A \sin(\omega t + \phi)$ at a given t , the answer would be incorrect.

one can represent a sine wave in terms of a cosine wave simply by introducing a phase shift of $\pi/2$ rad:

$$A \sin(\omega t) = A \cos\left(\omega t - \frac{\pi}{2}\right) \quad (4.22)$$

Although one usually employs the variable ω (in units of radians per second) to denote sinusoidal frequency, it is common to refer to natural frequency f in units of cycles per second, or **hertz (Hz)**. The reader with some training in music theory knows that a sinusoid represents what in music is called a *pure tone*; an A-440, for example, is a tone at a frequency of 440 Hz. It is important to be aware of the factor of 2π that differentiates radian frequency (in units of radians per second) from natural frequency (in units of hertz). The distinction between the two units of frequency—which are otherwise completely equivalent—is whether one chooses to define frequency in terms of revolutions around a trigonometric circle (in which case the resulting units are radians per second) or to interpret frequency as a repetition rate (cycles per second), in which case the units are hertz. The relationship between the two is the following:

$$\omega = 2\pi f \quad \text{Radian frequency} \quad (4.23)$$

Why Sinusoids?

By now you should have developed a healthy curiosity about why so much attention is being devoted to sinusoidal signals. Perhaps the simplest explanation is that the electric power used for industrial and household applications worldwide is generated and delivered in the form of either 50- or 60-Hz sinusoidal voltages and currents. Chapter 7 will provide more details regarding the analysis of electric power circuits. Note that the methods developed in this section and the subsequent sections apply to many engineering systems, not just to electric circuits, and will be encountered again in the study of dynamic-system modeling and of control systems.

Average and RMS Values

Now that a number of different signal waveforms have been defined, it is appropriate to define suitable measurements for quantifying the strength of a time-varying electric signal. The most common types of measurements are the **average** (or **DC**) **value** of a signal waveform—which corresponds to just measuring the mean voltage or current over a period of time—and the **root-mean-square** (or **rms**) **value**, which takes into account the fluctuations of the signal about its average value. Formally, the operation of computing the average value of a signal corresponds to integrating the signal waveform over some (presumably, suitably chosen) period of time. We define the time-averaged value of a signal $x(t)$ as

$$\langle x(t) \rangle = \frac{1}{T} \int_0^T x(t') dt' \quad \text{Average value} \quad (4.24)$$



where T is the period of integration. Figure 4.17 illustrates how this process does, in fact, correspond to computing the average amplitude of $x(t)$ over a period of T seconds.



Figure 4.17 Averaging a signal waveform

EXAMPLE 4.8 Average Value of Sinusoidal Waveform



Problem

Compute the average value of the signal $x(t) = 10 \cos(100t)$.

Solution

Known Quantities: Functional form of the periodic signal $x(t)$.

Find: Average value of $x(t)$.

Analysis: The signal is periodic with period $T = 2\pi/\omega = 2\pi/100$; thus we need to integrate over only one period to compute the average value:

$$\begin{aligned} \langle x(t) \rangle &= \frac{1}{T} \int_0^T x(t') dt' = \frac{100}{2\pi} \int_0^{2\pi/100} 10 \cos(100t) dt \\ &= \frac{10}{2\pi} (\sin(2\pi) - \sin(0)) = 0 \end{aligned}$$

Comments: The average value of a sinusoidal signal is zero, independent of its amplitude and frequency.

CHECK YOUR UNDERSTANDING

Express the voltage $v(t) = 155.6 \sin(377t + \pi/6)$ in cosine form. You should note that the radian frequency $\omega = 377$ will recur very often, since $377 = 2\pi(60)$; that is, 377 is the radian equivalent of the natural frequency of 60 cycles/s, which is the frequency of the electric power generated in North America.

Compute the average value of the sawtooth waveform shown in the figure below.

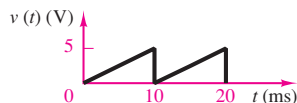

Compute the average value of the shifted triangle wave shown below.

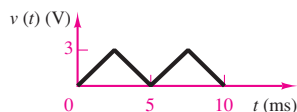

Answers: $v(t) = 155.6 \cos(377t - \pi/3)$; $\langle v(t) \rangle = 2.5 \text{ V}$; $\langle v(t) \rangle = 1.5 \text{ V}$

The result of Example 4.8 can be generalized to state that

$$\langle A \cos(\omega t + \phi) \rangle = 0 \quad (4.25)$$

a result that might be perplexing at first: If any sinusoidal voltage or current has zero average value, is its average power equal to zero? Clearly, the answer must be no. Otherwise, it would be impossible to illuminate households and streets and power industrial machinery with 60-Hz sinusoidal current! There must be another way, then, of quantifying the strength of an AC signal.

Very conveniently, a useful measure of the voltage of an AC waveform is the rms value of the signal $x(t)$, defined as follows:



$$x_{\text{rms}} = \sqrt{\frac{1}{T} \int_0^T x^2(t') dt'} \quad \text{Root-mean-square value} \quad (4.26)$$

Note immediately that if $x(t)$ is a voltage, the resulting x_{rms} will also have units of volts. If you analyze equation 4.26, you can see that, in effect, the rms value consists of the square root of the average (or mean) of the square of the signal. Thus, the notation *rms* indicates exactly the operations performed on $x(t)$ in order to obtain its rms value.

The definition of rms value does not help explain why one might be interested in using this quantity. The usefulness of rms values for AC signals in general, and for AC voltages and current in particular, can be explained easily with reference to Figure 4.18. In this figure, the same resistor is connected to two different voltage sources: a DC source and an AC source. We now ask, What is the *effective value* of the current from the DC source such that the *average power* dissipated by the resistor in the DC circuit is exactly the same as the *average power* dissipated by the same resistor in the AC circuit? The direct current I_{eff} is called the **effective value** of the alternating current, which is denoted by $i_{\text{ac}}(t)$. To answer this question, we assume that $v_{\text{ac}}(t)$ and therefore $i_{\text{ac}}(t)$ are periodic signals with period T . We then use the definition of average value of a signal given in equation 4.24 to compute the total energy dissipated by R during one period in the circuit of Figure 4.18(b):

$$W = TP_{AV} = T \langle p(t) \rangle = \int_0^T p(t') dt' = \int_0^T R i_{\text{ac}}^2(t') dt' = I_{\text{eff}}^2 R \quad (4.27)$$

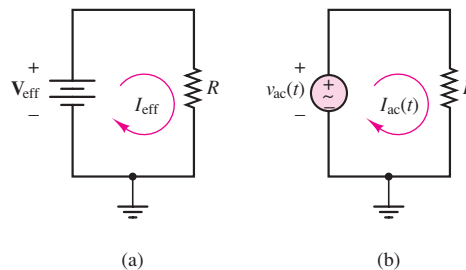

Figure 4.18 AC and DC circuits used to illustrate the concept of effective and rms values

Thus,

$$I_{\text{eff}} = \sqrt{\int_0^T i_{\text{ac}}^2(t') dt'} = I_{\text{rms}} \quad (4.28)$$

That is,

The rms, or effective, value of the current $i_{\text{ac}}(t)$ is the DC that causes the same average power (or energy) to be dissipated by the resistor.



From here on we shall use the notation V_{rms} , or \tilde{V} , and I_{rms} , or \tilde{I} , to refer to the effective (or rms) value of a voltage or current.

EXAMPLE 4.9 RMS Value of Sinusoidal Waveform



Problem

Compute the rms value of the sinusoidal current $i(t) = I \cos(\omega t)$.

Solution

Known Quantities: Functional form of the periodic signal $i(t)$.

Find: RMS value of $i(t)$.

Analysis: Applying the definition of rms value in equation 4.26, we compute

$$\begin{aligned} i_{\text{rms}} &= \sqrt{\frac{1}{T} \int_0^T i^2(t') dt'} = \sqrt{\frac{\omega}{2\pi} \int_0^{2\pi/\omega} I^2 \cos^2(\omega t') dt'} \\ &= \sqrt{\frac{\omega}{2\pi} \int_0^{2\pi/\omega} I^2 \left[\frac{1}{2} + \frac{1}{2} \cos(2\omega t') \right] dt'} \\ &= \sqrt{\frac{1}{2} I^2 + \frac{\omega}{2\pi} \int_0^{2\pi/\omega} \frac{I^2}{2} \cos(2\omega t') dt'} \end{aligned}$$

At this point, we recognize that the integral under the square root sign is equal to zero (see Example 4.8), because we are integrating a sinusoidal waveform over two periods. Hence,

$$i_{\text{rms}} = \frac{I}{\sqrt{2}} = 0.707I$$

where I is the *peak value* of the waveform $i(t)$.

Comments: The rms value of a sinusoidal signal is equal to 0.707 times the peak value, independent of its amplitude and frequency.

CHECK YOUR UNDERSTANDING

Find the rms value of the sawtooth wave of the exercise accompanying Example 4.8.
 Find the rms value of the half cosine wave shown in the next figure.

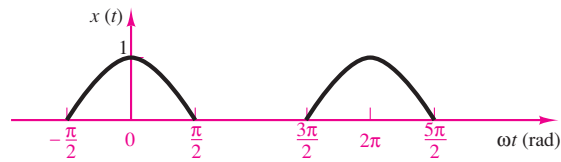

$$\begin{aligned}
 x(t) &= \cos t && \text{for } -\frac{\pi}{2} \leq \omega t < \frac{\pi}{2} \\
 &= 0 && \text{for } \frac{\pi}{2} \leq \omega t < \frac{3\pi}{2} \quad \omega = 1
 \end{aligned}$$

Answers: 2.89 V; 0.5 V

Example 4.9 illustrates how the rms value of a sinusoid is proportional to its peak amplitude. The factor of $0.707 = 1/\sqrt{2}$ is a useful number to remember, since it applies to any sinusoidal signal. It is not, however, generally applicable to signal waveforms other than sinusoids, as the Check Your Understanding exercises have illustrated.

4.3 SOLUTION OF CIRCUITS CONTAINING ENERGY STORAGE ELEMENTS (DYNAMIC CIRCUITS)

Sections 4.1 and 4.2 introduced energy storage elements and time-dependent signal sources. The logical next task is to analyze the behavior of circuits containing such elements. The major difference between the analysis of the resistive circuits studied in Chapters 2 and 3 and the circuits we explore in the remainder of this chapter is that now the equations that result from applying Kirchhoff's laws are differential equations, as opposed to the algebraic equations obtained in solving resistive circuits. Consider, for example, the circuit of Figure 4.19, which consists of the series connection of a voltage source, a resistor, and a capacitor. Applying KCL at the node connecting the resistor to the capacitor and using the definition of capacitor current in equation 4.4, we obtain the following equations:



A circuit containing energy-storage elements is described by a differential equation. The differential equation describing the series RC circuit shown is

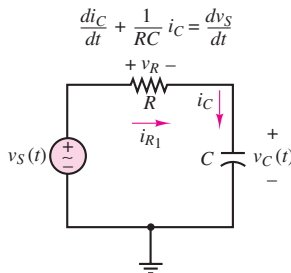

Figure 4.19 Circuit containing energy storage element

$$i_R(t) = \frac{v_S(t) - v_C(t)}{R} = i_C(t) = C \frac{dv_C(t)}{dt} \tag{4.29}$$

or

$$\frac{dv_C(t)}{dt} + \frac{1}{RC} v_C(t) = \frac{1}{RC} v_S(t) \tag{4.30}$$

Equation 4.30 is a first-order, linear, ordinary differential equation in the variable v_C . Alternatively, we could derive an equivalent relationship by applying KVL around the circuit of Figure 4.19:

$$-v_S(t) + v_R(t) + v_C(t) = 0 \tag{4.31}$$

Observing that $i_R(t) = i_C(t)$ and using the capacitor equation 4.5, we can write

$$-v_S(t) + Ri_C(t) + \frac{1}{C} \int_{-\infty}^t i_C(t') dt' = 0 \quad (4.32)$$

Equation 4.32 is an integral equation, which may be converted to the more familiar form of a differential equation by differentiating both sides; recalling that

$$\frac{d}{dt} \left[\int_{-\infty}^t i_C(t') dt' \right] = i_C(t) \quad (4.33)$$

we obtain the first-order, linear, ordinary differential equation

$$\frac{di_C(t)}{dt} + \frac{1}{RC} i_C(t) = \frac{1}{R} \frac{dv_S(t)}{dt} \quad (4.34)$$

Equations 4.30 and 4.34 are very similar; the principal differences are the variable in the differential equation [$v_C(t)$ versus $i_C(t)$] and the right-hand side. Solving either equation for the unknown variable permits the computation of all voltages and currents in the circuit.

Note to the Instructor: If so desired, the remainder of this chapter can be skipped, and the course can continue with Chapter 5 without any loss of continuity.

Forced Response of Circuits Excited by Sinusoidal Sources

Consider again the circuit of Figure 4.19, where now the external source produces a sinusoidal voltage, described by the expression

$$v_S(t) = V \cos \omega t \quad (4.35)$$

Substituting the expression $V \cos(\omega t)$ in place of the source voltage $v_S(t)$ in the differential equation obtained earlier (equation 4.30), we obtain the following differential equation:

$$\frac{d}{dt} v_C + \frac{1}{RC} v_C = \frac{1}{RC} V \cos \omega t \quad (4.36)$$

Since the forcing function is a sinusoid, the solution may also be assumed to be of the same form. An expression for $v_C(t)$ is then

$$v_C(t) = A \sin \omega t + B \cos \omega t \quad (4.37)$$

which is equivalent to

$$v_C(t) = C \cos(\omega t + \phi) \quad (4.38)$$

Substituting equation 4.37 in the differential equation for $v_C(t)$ and solving for the coefficients A and B yield the expression

$$\begin{aligned} A\omega \cos \omega t - B\omega \sin \omega t + \frac{1}{RC} (A \sin \omega t + B \cos \omega t) \\ = \frac{1}{RC} V \cos \omega t \end{aligned} \quad (4.39)$$

and if the coefficients of like terms are grouped, the following equation is obtained:

$$\left(\frac{A}{RC} - B\omega\right) \sin \omega t + \left(A\omega + \frac{B}{RC} - \frac{V}{RC}\right) \cos \omega t = 0 \quad (4.40)$$

The coefficients of $\sin \omega t$ and $\cos \omega t$ must both be identically zero in order for equation 4.40 to hold. Thus,

$$\frac{A}{RC} - B\omega = 0$$

and (4.41)

$$A\omega + \frac{B}{RC} - \frac{V}{RC} = 0$$

The unknown coefficients A and B may now be determined by solving equation 4.41:

$$A = \frac{V\omega RC}{1 + \omega^2(RC)^2} \quad (4.42)$$

$$B = \frac{V}{1 + \omega^2(RC)^2}$$

Thus, the solution for $v_C(t)$ may be written as follows:

$$v_C(t) = \frac{V\omega RC}{1 + \omega^2(RC)^2} \sin \omega t + \frac{V}{1 + \omega^2(RC)^2} \cos \omega t \quad (4.43)$$

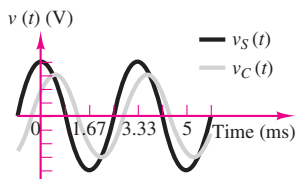

Figure 4.20 Waveforms for the AC circuit of Figure 4.19

This response is plotted in Figure 4.20.

The solution method outlined in the previous paragraphs can become quite complicated for circuits containing a large number of elements; in particular, one may need to solve higher-order differential equations if more than one energy storage element is present in the circuit. A simpler and preferred method for the solution of AC circuits is presented in Section 4.4. This brief section has provided a simple, but complete illustration of the key elements of AC circuit analysis. These can be summarized in the following statement:



In a sinusoidally excited linear circuit, all branch voltages and currents are *sinusoids* at the *same frequency* as the excitation signal. The amplitudes of these voltages and currents are a *scaled* version of the excitation *amplitude*, and the voltages and currents may be *shifted in phase* with respect to the excitation signal.

These observations indicate that three parameters uniquely define a sinusoid: *frequency*, *amplitude*, and *phase*. But if this is the case, is it necessary to carry the “excess luggage,” that is, the sinusoidal functions? Might it be possible to simply keep track of the three parameters just mentioned? Fortunately, the answers to these two questions are no and yes, respectively. Section 4.4 describes the use of a notation that, with the aid of complex algebra, eliminates the need for the sinusoidal functions of time, and for the formulation and solution of differential equations, permitting the use of simpler algebraic methods.

4.4 PHASOR SOLUTION OF CIRCUITS WITH SINUSOIDAL EXCITATION

In this section, we introduce an efficient notation to make it possible to represent sinusoidal signals as *complex numbers*, and to eliminate the need for solving differential equations. The student who needs a brief review of complex algebra will find a reasonably complete treatment in Appendix A (available online), including solved examples and Check Your Understanding exercises. For the remainder of the chapter, it will be assumed that you are familiar with both the rectangular and the polar forms of complex number coordinates; with the conversion between these two forms; and with the basic operations of addition, subtraction, multiplication, and division of complex numbers.

Euler's Identity

Named after the Swiss mathematician Leonhard Euler (the last name is pronounced "Oiler"), Euler's identity forms the basis of phasor notation. Simply stated, the identity defines the **complex exponential** $e^{j\theta}$ as a point in the complex plane, which may be represented by real and imaginary components:

$$e^{j\theta} = \cos \theta + j \sin \theta \quad (4.44)$$

Figure 4.21 illustrates how the complex exponential may be visualized as a point (or vector, if referenced to the origin) in the complex plane. Note immediately that the magnitude of $e^{j\theta}$ is equal to 1:

$$|e^{j\theta}| = 1 \quad (4.45)$$

since

$$|\cos \theta + j \sin \theta| = \sqrt{\cos^2 \theta + \sin^2 \theta} = 1 \quad (4.46)$$

and note also that writing Euler's identity corresponds to equating the polar form of a complex number to its rectangular form. For example, consider a vector of length A making an angle θ with the real axis. The following equation illustrates the relationship between the rectangular and polar forms:

$$Ae^{j\theta} = A \cos \theta + jA \sin \theta = A \angle \theta \quad (4.47)$$

In effect, Euler's identity is simply a trigonometric relationship in the complex plane.

Phasors

To see how complex numbers can be used to represent sinusoidal signals, rewrite the expression for a generalized sinusoid in light of Euler's equation:

$$A \cos(\omega t + \theta) = \text{Re} (Ae^{j(\omega t + \theta)}) \quad (4.48)$$

This equality is easily verified by expanding the right-hand side, as follows:

$$\begin{aligned} \text{Re} (Ae^{j(\omega t + \theta)}) &= \text{Re} [A \cos(\omega t + \theta) + jA \sin(\omega t + \theta)] \\ &= A \cos(\omega t + \theta) \end{aligned}$$

We see, then, that *it is possible to express a generalized sinusoid as the real part of a complex vector whose argument, or angle, is given by $\omega t + \theta$ and whose length, or magnitude, is equal to the peak amplitude of the sinusoid. The **complex phasor***



Leonhard Euler (1707–1783).
Photograph courtesy of
Deutsches Museum, Munich.

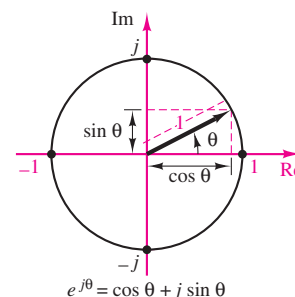

Figure 4.21 Euler's identity

corresponding to the sinusoidal signal $A \cos(\omega t + \theta)$ is therefore defined to be the complex number $Ae^{j\theta}$:

$$Ae^{j\theta} = \text{complex phasor notation for } A \cos(\omega t + \theta) = A \angle \theta \quad (4.49)$$

It is important to explicitly point out that this is a *definition*. Phasor notation arises from equation 4.48; however, this expression is simplified (for convenience, as will be promptly shown) by removing the “real part of” operator (Re) and factoring out and deleting the term $e^{j\omega t}$. Equation 4.50 illustrates the simplification:

$$A \cos(\omega t + \theta) = \text{Re} (Ae^{j(\omega t + \theta)}) = \text{Re} (Ae^{j\theta} e^{j\omega t}) \quad (4.50)$$

The reason for this simplification is simply mathematical convenience, as will become apparent in the following examples; you will have to remember that the $e^{j\omega t}$ term that was removed from the complex form of the sinusoid is really still present, indicating the specific frequency of the sinusoidal signal ω . With these caveats, you should now be prepared to use the newly found phasor to analyze AC circuits. The following comments summarize the important points developed thus far in the section. Please note that the concept of phasor has no real physical significance. It is a convenient mathematical tool that simplifies the solution of AC circuits.



FOCUS ON METHODOLOGY

1. Any sinusoidal signal may be mathematically represented in one of two ways: a **time-domain form**

$$v(t) = A \cos(\omega t + \theta)$$

and a **frequency-domain (or phasor) form**

$$\mathbf{V}(j\omega) = Ae^{j\theta} = A \angle \theta$$

Note the $j\omega$ in the notation $\mathbf{V}(j\omega)$, indicating the $e^{j\omega t}$ dependence of the phasor. In the remainder of this chapter, bold uppercase quantities indicate phasor voltages or currents.

2. A phasor is a complex number, expressed in polar form, consisting of a *magnitude* equal to the peak amplitude of the sinusoidal signal and a *phase angle* equal to the phase shift of the sinusoidal signal *referenced to a cosine signal*.
3. When one is using phasor notation, it is important to note the specific frequency ω of the sinusoidal signal, since this is not explicitly apparent in the phasor expression.



EXAMPLE 4.10 Addition of Two Sinusoidal Sources in Phasor Notation

Problem

Compute the phasor voltage resulting from the series connection of two sinusoidal voltage sources (Figure 4.22).

Solution**Known Quantities:**

$$v_1(t) = 15 \cos\left(377t + \frac{\pi}{4}\right) \quad \text{V}$$

$$v_2(t) = 15 \cos\left(377t + \frac{\pi}{12}\right) \quad \text{V}$$

Find: Equivalent phasor voltage $v_S(t)$.**Analysis:** Write the two voltages in phasor form:

$$\mathbf{V}_1(j\omega) = 15\angle\frac{\pi}{4} \quad \text{V}$$

$$\mathbf{V}_2(j\omega) = 15e^{j\pi/12} = 15\angle\frac{\pi}{12} \quad \text{V}$$

Convert the phasor voltages from polar to rectangular form:

$$\mathbf{V}_1(j\omega) = 10.61 + j10.61 \quad \text{V}$$

$$\mathbf{V}_2(j\omega) = 14.49 + j3.88 \quad \text{V}$$

Then

$$\mathbf{V}_S(j\omega) = \mathbf{V}_1(j\omega) + \mathbf{V}_2(j\omega) = 25.10 + j14.49 = 28.98e^{j\pi/6} = 28.98\angle\frac{\pi}{6} \quad \text{V}$$

Now we can convert $\mathbf{V}_S(j\omega)$ to its time-domain form:

$$v_S(t) = 28.98 \cos\left(377t + \frac{\pi}{6}\right) \quad \text{V}$$

Comments: Note that we could have obtained the same result by adding the two sinusoids in the time domain, using trigonometric identities:

$$v_1(t) = 15 \cos\left(377t + \frac{\pi}{4}\right) = 15 \cos\frac{\pi}{4} \cos(377t) - 15 \sin\frac{\pi}{4} \sin(377t) \quad \text{V}$$

$$v_2(t) = 15 \cos\left(377t + \frac{\pi}{12}\right) = 15 \cos\frac{\pi}{12} \cos(377t) - 15 \sin\frac{\pi}{12} \sin(377t) \quad \text{V}$$

Combining like terms, we obtain

$$\begin{aligned} v_1(t) + v_2(t) &= 15 \left(\cos\frac{\pi}{4} + \cos\frac{\pi}{12} \right) \cos(377t) - 15 \left(\sin\frac{\pi}{4} + \sin\frac{\pi}{12} \right) \sin(377t) \\ &= 15[1.673 \cos(377t) - 0.966 \sin(377t)] \\ &= 15\sqrt{(1.673)^2 + (0.966)^2} \times \cos\left[377t + \arctan\left(\frac{0.966}{1.673}\right)\right] \\ &= 15 \left[1.932 \cos\left(377t + \frac{\pi}{6}\right) \right] = 28.98 \cos\left(377t + \frac{\pi}{6}\right) \quad \text{V} \end{aligned}$$

The above expression is, of course, identical to the one obtained by using phasor notation, but it required a greater amount of computation. In general, phasor analysis greatly simplifies calculations related to sinusoidal voltages and currents.

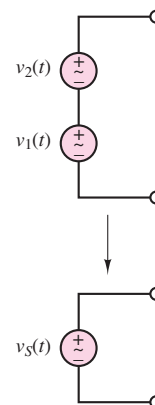

Figure 4.22

CHECK YOUR UNDERSTANDING

Add the sinusoidal voltages $v_1(t) = A \cos(\omega t + \phi)$ and $v_2(t) = B \cos(\omega t + \theta)$ using phasor notation, and then convert back to time-domain form.

- a. $A = 1.5 \text{ V}, \phi = 10^\circ; B = 3.2 \text{ V}, \theta = 25^\circ.$
- b. $A = 50 \text{ V}, \phi = -60^\circ; B = 24 \text{ V}, \theta = 15^\circ.$

Answers: (a) $v_1 + v_2 = 4.67 \cos(\omega t + 0.3526 \text{ rad})$; (b) $v_1 + v_2 = 60.8 \cos(\omega t - 0.6562 \text{ rad})$

It should be apparent by now that phasor notation can be a very efficient technique to solve AC circuit problems. The following sections continue to develop this new method to build your confidence in using it.

Superposition of AC Signals

Example 4.10 explored the combined effect of two sinusoidal sources of different phase and amplitude, but of the same frequency. It is important to realize that the simple answer obtained there does not apply to the superposition of two (or more) sinusoidal sources that *are not at the same frequency*. In this subsection, the case of two sinusoidal sources oscillating at different frequencies is used to illustrate how phasor analysis can deal with this, more general case.

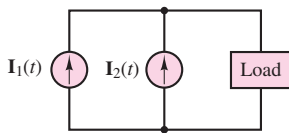

Figure 4.23 Superposition of AC

The circuit shown in Figure 4.23 depicts a source excited by two current sources connected in parallel, where

$$i_1(t) = A_1 \cos(\omega_1 t) \tag{4.51}$$

$$i_2(t) = A_2 \cos(\omega_2 t)$$

The load current is equal to the sum of the two source currents; that is,

$$i_L(t) = i_1(t) + i_2(t) \tag{4.52}$$

or, in phasor form,

$$\mathbf{I}_L = \mathbf{I}_1 + \mathbf{I}_2 \tag{4.53}$$

At this point, you might be tempted to write \mathbf{I}_1 and \mathbf{I}_2 in a more explicit phasor form as

$$\mathbf{I}_1 = A_1 e^{j0} \tag{4.54}$$

$$\mathbf{I}_2 = A_2 e^{j0}$$

and to add the two phasors, using the familiar techniques of complex algebra. However, this approach *would be incorrect*. Whenever a sinusoidal signal is expressed in phasor notation, the term $e^{j\omega t}$ is implicitly present, where ω is the actual radian frequency of the signal. In our example, the two frequencies are not the same, as can be verified by writing the phasor currents in the form of equation 4.50:

$$\mathbf{I}_1 = \text{Re} (A_1 e^{j0} e^{j\omega_1 t}) \tag{4.55}$$

$$\mathbf{I}_2 = \text{Re} (A_2 e^{j0} e^{j\omega_2 t})$$

Since phasor notation does not *explicitly* include the $e^{j\omega t}$ factor, this can lead to serious errors if you are not careful! The two phasors of equation 4.54 cannot be added, but must be kept separate; thus, the only unambiguous expression for the load

current in this case is equation 4.52. To complete the analysis of any circuit with multiple sinusoidal sources at different frequencies using phasors, it is necessary to solve the circuit separately for each signal and then add the individual answers obtained for the different excitation sources. Example 4.11 illustrates the response of a circuit with two separate AC excitations using AC superposition.

EXAMPLE 4.11 AC Superposition

Problem

This example underscores the importance of the principles of superposition. In the case of sinusoidal sources at different frequencies, solution by superposition is the *only* viable method. Compute the voltages $v_{R1}(t)$ and $v_{R2}(t)$ in the circuit of Figure 4.24.

Solution

Known Quantities:

$$i_S(t) = 0.5 \cos[2\pi(100t)] \quad \text{A}$$

$$v_S(t) = 20 \cos[2\pi(1,000t)] \quad \text{V}$$

Find: $v_{R1}(t)$ and $v_{R2}(t)$.

Analysis: Since the two sources are at different frequencies, we must compute a separate solution for each. Consider the current source first, with the voltage source set to zero (short circuit) as shown in Figure 4.25. The circuit thus obtained is a simple current divider. Write the source current in phasor notation:

$$\mathbf{I}_S(j\omega) = 0.5e^{j0} = 0.5\angle 0 \quad \text{A} \quad \omega = 2\pi(100) \text{ rad/s}$$

Then

$$\mathbf{V}_{R1}(\mathbf{I}_S) = \mathbf{I}_S \frac{R_2}{R_1 + R_2} R_1 = 0.5\angle 0 \left(\frac{50}{150 + 50} \right) 150 = 18.75\angle 0 \quad \text{V}$$

$$\omega = 2\pi(100) \text{ rad/s}$$

$$\mathbf{V}_{R2}(\mathbf{I}_S) = \mathbf{I}_S \frac{R_1}{R_1 + R_2} R_2 = 0.5\angle 0 \left(\frac{150}{150 + 50} \right) 50 = 18.75\angle 0 \quad \text{V}$$

$$\omega = 2\pi(100) \text{ rad/s}$$

Next, we consider the voltage source, with the current source set to zero (open circuit), as shown in Figure 4.26. We first write the source voltage in phasor notation:

$$\mathbf{V}_S(j\omega) = 20e^{j0} = 20\angle 0 \quad \text{V} \quad \omega = 2\pi(1,000) \text{ rad/s}$$

Then we apply the voltage divider law, to obtain

$$\mathbf{V}_{R1}(\mathbf{V}_S) = \mathbf{V}_S \frac{R_1}{R_1 + R_2} = 20\angle 0 \left(\frac{150}{150 + 50} \right) = 15\angle 0 \quad \text{V}$$

$$\omega = 2\pi(1,000) \text{ rad/s}$$

$$\mathbf{V}_{R2}(\mathbf{V}_S) = -\mathbf{V}_S \frac{R_2}{R_1 + R_2} = -20\angle 0 \left(\frac{50}{150 + 50} \right) = -5\angle 0 = 5\angle \pi \quad \text{V}$$

$$\omega = 2\pi(1,000) \text{ rad/s}$$

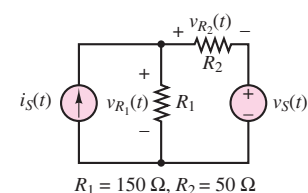

Figure 4.24

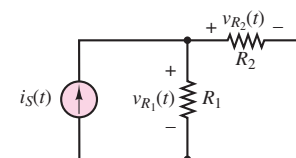

Figure 4.25

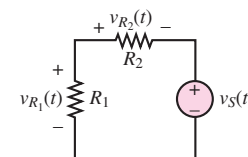

Figure 4.26

Now we can determine the voltage across each resistor by adding the contributions from each source and converting the phasor form to time-domain representation:

$$\mathbf{V}_{R1} = \mathbf{V}_{R1}(\mathbf{I}_S) + \mathbf{V}_{R1}(\mathbf{V}_S)$$

$$v_{R1}(t) = 18.75 \cos[2\pi(100t)] + 15 \cos[2\pi(1,000t)] \quad \text{V}$$

and

$$\mathbf{V}_{R2} = \mathbf{V}_{R2}(\mathbf{I}_S) + \mathbf{V}_{R2}(\mathbf{V}_S)$$

$$v_{R2}(t) = 18.75 \cos[2\pi(100t)] + 5 \cos[2\pi(1,000t) + \pi] \quad \text{V}$$

Comments: Note that it is impossible to simplify the final expression any further because the two components of each voltage are at different frequencies.

CHECK YOUR UNDERSTANDING

Add the sinusoidal currents $i_1(t) = A \cos(\omega t + \phi)$ and $i_2(t) = B \cos(\omega t + \theta)$ for

- $A = 0.09 \text{ A}$, $\phi = 72^\circ$; $B = 0.12 \text{ A}$, $\theta = 20^\circ$.
- $A = 0.82 \text{ A}$, $\phi = -30^\circ$; $B = 0.5 \text{ A}$, $\theta = -36^\circ$.

Answers: (a) $i_1 + i_2 = 0.19 \cos(\omega t + 0.733)$; (b) $i_1 + i_2 = 1.32 \cos(\omega t - 0.5637)$

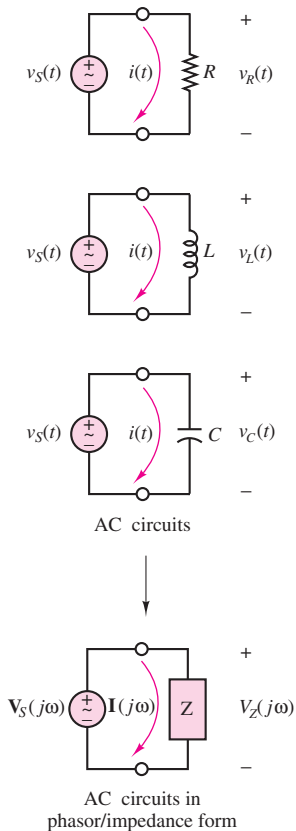

Impedance

We now analyze the i - v relationship of the three ideal circuit elements in light of the new phasor notation. The result will be a new formulation in which resistors, capacitors, and inductors will be described in the same notation. A direct consequence of this result will be that the circuit theorems of Chapter 3 will be extended to AC circuits. In the context of AC circuits, any one of the three ideal circuit elements defined so far will be described by a parameter called **impedance**, which may be viewed as a *complex resistance*. The impedance concept is equivalent to stating that capacitors and inductors act as *frequency-dependent resistors*, that is, as resistors whose resistance is a function of the frequency of the sinusoidal excitation. Figure 4.27 depicts the same circuit represented in conventional form (top) and in phasor-impedance form (bottom); the latter representation explicitly shows phasor voltages and currents and treats the circuit element as a generalized “impedance.” It will presently be shown that each of the three ideal circuit elements may be represented by one such impedance element.

Let the source voltage in the circuit of Figure 4.27 be defined by

$$v_S(t) = A \cos \omega t \quad \text{or} \quad \mathbf{V}_S(j\omega) = Ae^{j0^\circ} = A\angle 0 \quad (4.56)$$

without loss of generality. Then the current $i(t)$ is defined by the i - v relationship for each circuit element. Let us examine the frequency-dependent properties of the resistor, inductor, and capacitor, one at a time.

Figure 4.27 The impedance element

The Resistor

Ohm's law dictates the well-known relationship $v = iR$. In the case of sinusoidal sources, then, the current flowing through the resistor of Figure 4.27 may be expressed as

$$i(t) = \frac{v_S(t)}{R} = \frac{A}{R} \cos \omega t \tag{4.57}$$

Converting the voltage $v_S(t)$ and the current $i(t)$ to phasor notation, we obtain the following expressions:

$$\begin{aligned} \mathbf{V}_Z(j\omega) &= A \angle 0 \\ \mathbf{I}(j\omega) &= \frac{A}{R} \angle 0 \end{aligned} \tag{4.58}$$

The relationship between \mathbf{V}_Z and \mathbf{I} in the complex plane is shown in Figure 4.28. Finally, the *impedance* of the resistor is defined as the ratio of the phasor voltage across the resistor to the phasor current flowing through it, and the symbol Z_R is used to denote it:

$$Z_R(j\omega) = \frac{\mathbf{V}_Z(j\omega)}{\mathbf{I}(j\omega)} = R \quad \text{Impedance of a resistor} \tag{4.59}$$

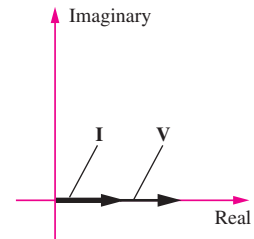

Figure 4.28 Phasor voltage and current relationships for a resistor



Equation 4.59 corresponds to Ohm's law in phasor form, and the result should be intuitively appealing: Ohm's law applies to a resistor independent of the particular form of the voltages and currents (whether AC or DC, for instance). The ratio of phasor voltage to phasor current has a very simple form in the case of the resistor. In general, however, the impedance of an element is a complex function of frequency, as it must be, since it is the ratio of two phasor quantities, which are frequency-dependent. This property will become apparent when the impedances of the inductor and capacitor are defined.

The Inductor

Recall the defining relationships for the ideal inductor (equations 4.10 and 4.13), repeated here for convenience:

$$\begin{aligned} v_L(t) &= L \frac{di_L(t)}{dt} \\ i_L(t) &= \frac{1}{L} \int v_L(t') \end{aligned} \tag{4.60}$$

Let $v_L(t) = v_S(t)$ and $i_L(t) = i(t)$ in the circuit of Figure 4.27. Then the following expression may be derived for the inductor current:

$$\begin{aligned} i_L(t) &= i(t) = \frac{1}{L} \int v_S(t') dt' \\ i_L(t) &= \frac{1}{L} \int A \cos \omega t' dt' \\ &= \frac{A}{\omega L} \sin \omega t \end{aligned} \tag{4.61}$$

Note how a dependence on the radian frequency of the source is clearly present in the expression for the inductor current. Further, the inductor current is shifted in phase (by 90°) with respect to the voltage. This fact can be seen by writing the inductor voltage and current in time-domain form:

$$\begin{aligned} v_S(t) &= v_L(t) = A \cos \omega t \\ i(t) &= i_L(t) = \frac{A}{\omega L} \cos \left(\omega t - \frac{\pi}{2} \right) \end{aligned} \quad (4.62)$$

It is evident that the current is not just a scaled version of the source voltage, as it was for the resistor. Its magnitude depends on the frequency ω , and it is shifted (delayed) in phase by $\pi/2$ rad, or 90° . Using phasor notation, equation 4.62 becomes

$$\begin{aligned} \mathbf{V}_Z(j\omega) &= A \angle 0 \\ \mathbf{I}(j\omega) &= \frac{A}{\omega L} \angle -\frac{\pi}{2} \end{aligned} \quad (4.63)$$

The relationship between the phasor voltage and current is shown in Figure 4.29. Thus, the impedance of the inductor is defined as follows:



$$\mathbf{Z}_L(j\omega) = \frac{\mathbf{V}_Z(j\omega)}{\mathbf{I}(j\omega)} = \omega L \angle \frac{\pi}{2} = j\omega L \quad \text{Impedance of an inductor} \quad (4.64)$$

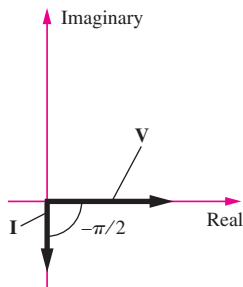

Figure 4.29 Phasor voltage and current relationships for an inductor

Note that the inductor now appears to behave as a *complex frequency-dependent resistor*, and that the magnitude of this complex resistor ωL is proportional to the signal frequency ω . Thus, an inductor will “impede” current flow in proportion to the sinusoidal frequency of the source signal. This means that at low signal frequencies, an inductor acts somewhat as a short circuit, while at high frequencies it tends to behave more as an open circuit.

The Capacitor

An analogous procedure may be followed to derive the equivalent result for a capacitor. Beginning with the defining relationships for the ideal capacitor

$$i_C(t) = C \frac{dv_C(t)}{dt} \quad (4.65)$$

$$v_C(t) = \frac{1}{C} \int i_C(t') dt'$$

with $i_C = i$ and $v_C = v_S$ in Figure 4.27, we can express the capacitor current as

$$\begin{aligned} i_C(t) &= C \frac{dv_C(t)}{dt} \\ &= C \frac{d}{dt} (A \cos \omega t) \\ &= -C(A\omega \sin \omega t) \\ &= \omega CA \cos \left(\omega t + \frac{\pi}{2} \right) \end{aligned} \quad (4.66)$$

so that, in phasor form,

$$\begin{aligned} \mathbf{V}_Z(j\omega) &= A\mathbf{I} \\ \mathbf{I}(j\omega) &= \omega C A \angle \frac{\pi}{2} \end{aligned} \tag{4.67}$$

The relationship between the phasor voltage and current is shown in Figure 4.30. The impedance of the ideal capacitor $Z_C(j\omega)$ is therefore defined as follows:

$$\begin{aligned} Z_C(j\omega) &= \frac{\mathbf{V}_Z(j\omega)}{\mathbf{I}(j\omega)} = \frac{1}{\omega C} \angle \frac{-\pi}{2} \\ &= \frac{-j}{\omega C} = \frac{1}{j\omega C} \end{aligned} \quad \text{Impedance of a capacitor} \tag{4.68}$$

where we have used the fact that $1/j = e^{-j\pi/2} = -j$. Thus, the impedance of a capacitor is also a frequency-dependent complex quantity, with the impedance of the capacitor varying as an inverse function of frequency; and so a capacitor acts as a short circuit at high frequencies, whereas it behaves more as an open circuit at low frequencies. Figure 4.31 depicts $Z_C(j\omega)$ in the complex plane, alongside $Z_R(j\omega)$ and $Z_L(j\omega)$.

The impedance parameter defined in this section is extremely useful in solving AC circuit analysis problems, because it will make it possible to take advantage of most of the network theorems developed for DC circuits by replacing resistances with complex-valued impedances. Examples 4.12 to 4.14 illustrate how branches containing series and parallel elements may be reduced to a single equivalent impedance, much in the same way as resistive circuits were reduced to equivalent forms. It is important to emphasize that although the impedance of simple circuit elements is either purely real (for resistors) or purely imaginary (for capacitors and inductors), the general definition of impedance for an arbitrary circuit must allow for the possibility of having both a real and an imaginary part, since practical circuits are made up of more or less complex interconnections of different circuit elements. In its most general form, the impedance of a circuit element is defined as the sum of a real part and an imaginary part

$$Z(j\omega) = R(j\omega) + jX(j\omega) \tag{4.69}$$

where R is the **real part of the impedance**, sometimes called the **AC resistance** and X is the **imaginary part of the impedance**, also called the **reactance**. The frequency dependence of R and X has been indicated explicitly, since it is possible for a circuit to have a frequency-dependent resistance. Note that the reactances of equations 4.64 and 4.68 have units of ohms, and that **inductive reactance** is always positive, while **capacitive reactance** is always negative. Examples 4.12 to 4.14 illustrate how a complex impedance containing both real and imaginary parts arises in a circuit. Impedance is another useful mathematical tool that is convenient in solving AC circuits, but has no real physical significance. *Please note that the impedance $Z(j\omega)$ is not a phasor, but just a complex number.*

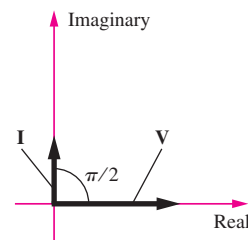

Figure 4.30 Phasor voltage and current relationships for a capacitor

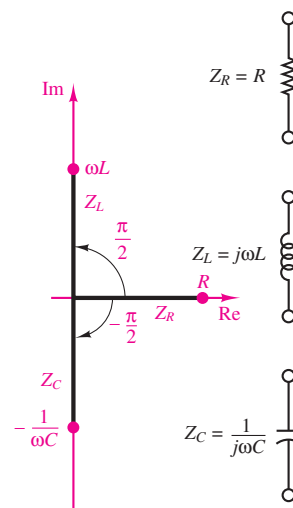

Figure 4.31 Impedances of R , L , and C in the complex plane



EXAMPLE 4.12 Impedance of a Practical Capacitor

Problem

A practical capacitor can be modeled by an ideal capacitor in parallel with a resistor. The parallel resistance represents leakage losses in the capacitor and is usually quite large. Find the impedance of a practical capacitor at the radian frequency $\omega = 377$ rad/s (60 Hz). How will the impedance change if the capacitor is used at a much higher frequency, say, 800 kHz?

Solution

Known Quantities: Figure 4.32; $C_1 = 0.001 \mu\text{F} = 1 \times 10^{-9}$ F; $R_1 = 1 \text{ M}\Omega$.

Find: The equivalent impedance of the parallel circuit Z_1 .

Analysis: To determine the equivalent impedance, we combine the two impedances in parallel.

$$Z_1 = R_1 \parallel \frac{1}{j\omega C_1} = \frac{R_1(1/j\omega C_1)}{R_1 + 1/j\omega C_1} = \frac{R_1}{1 + j\omega C_1 R_1}$$

Substituting numerical values, we find

$$\begin{aligned} Z_1(\omega = 377) &= \frac{10^6}{1 + j377 \times 10^6 \times 10^{-9}} = \frac{10^6}{1 + j0.377} \\ &= 9.3571 \times 10^5 \angle(-0.3605) \Omega \end{aligned}$$

The impedance of the capacitor alone at this frequency would be

$$Z_{C_1}(\omega = 377) = \frac{1}{j377 \times 10^{-9}} = 2.6525 \times 10^6 \angle\left(-\frac{\pi}{2}\right) \Omega$$

You can easily see that the parallel impedance Z_1 is quite different from the impedance of the capacitor alone, Z_{C_1} .

If the frequency is increased to 800 kHz, or $1600\pi \times 10^3$ rad/s—a radio frequency in the AM range—we can recompute the impedance to be

$$\begin{aligned} Z_1(\omega = 1600\pi \times 10^3) &= \frac{10^6}{1 + j1,600\pi \times 10^3 \times 10^{-9} \times 10^6} \\ &= \frac{10^6}{1 + j1,600\pi} = 198.9 \angle(-1.5706) \Omega \end{aligned}$$

The impedance of the capacitor alone at this frequency would be

$$Z_{C_1}(\omega = 1,600\pi \times 10^3) = \frac{1}{j1,600\pi \times 10^3 \times 10^{-9}} = 198.9 \angle\left(-\frac{\pi}{2}\right) \Omega$$

Now, the impedances Z_1 and Z_{C_1} are virtually identical (note that $\pi/2 = 1.5708$ rad). Thus, the effect of the parallel resistance is negligible at high frequencies.

Comments: The effect of the parallel resistance at the lower frequency (corresponding to the well-known 60-Hz AC power frequency) is significant: The effective impedance of the practical capacitor is substantially different from that of the ideal capacitor. On the other

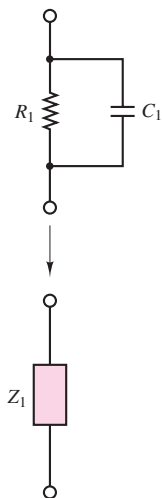

Figure 4.32

hand, at much higher frequency, the parallel resistance has an impedance so much larger than that of the capacitor that it effectively acts as an open circuit, and there is no difference between the ideal and practical capacitor impedances. This example suggests that the behavior of a circuit element depends very much on the frequency of the voltages and currents in the circuit.

EXAMPLE 4.13 Impedance of a Practical Inductor



Problem

A practical inductor can be modeled by an ideal inductor in series with a resistor. Figure 4.33 shows a *toroidal* (doughnut-shaped) inductor. The series resistance represents the resistance of the coil wire and is usually small. Find the range of frequencies over which the impedance of this practical inductor is largely *inductive* (i.e., due to the inductance in the circuit). We shall consider the impedance to be inductive if the impedance of the inductor in the circuit of Figure 4.34 is at least 10 times as large as that of the resistor.

Solution

Known Quantities: $L = 0.098$ H; lead length = $l_c = 2 \times 10$ cm; $n = 250$ turns; wire is 30-gauge. Resistance of 30-gauge wire = $0.344 \Omega/\text{m}$.

Find: The range of frequencies over which the practical inductor acts nearly as an ideal inductor.

Analysis: We first determine the equivalent resistance of the wire used in the practical inductor, using the cross section as an indication of the wire length l_w in the coil:

$$l_w = 250(2 \times 0.25 + 2 \times 0.5) = 375 \text{ cm}$$

$$l = \text{total length} = l_w + l_c = 375 + 20 = 395 \text{ cm}$$

The total resistance is therefore

$$R = 0.344 \Omega/\text{m} \times 0.395 \text{ m} = 0.136 \Omega$$

Thus, we wish to determine the range of radian frequencies, ω , over which the magnitude of $j\omega L$ is greater than $10 \times 0.136 \Omega$:

$$\omega L > 1.36 \quad \text{or} \quad \omega > \frac{1.36}{L} = \frac{1.36}{0.098} = 1.39 \text{ rad/s}$$

Alternatively, the range is $f = \omega/2\pi > 0.22$ Hz.

Comments: Note how the resistance of the coil wire is relatively insignificant. This is true because the inductor is rather large; wire resistance can become significant for very small inductance values. At high frequencies, a capacitance should be added to the model because of the effect of the insulator separating the coil wires.

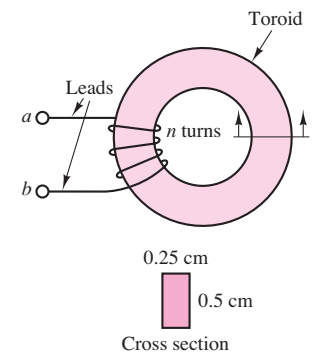

Figure 4.33 A practical inductor

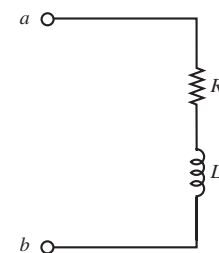

Figure 4.34

EXAMPLE 4.14 Impedance of a More Complex Circuit



Problem

Find the equivalent impedance of the circuit shown in Figure 4.35.

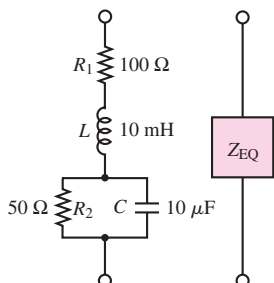

Figure 4.35

Solution

Known Quantities: $\omega = 10^4$ rad/s; $R_1 = 100 \Omega$; $L = 10$ mH; $R_2 = 50 \Omega$; $C = 10 \mu\text{F}$.

Find: The equivalent impedance of the series-parallel circuit.

Analysis: We determine first the parallel impedance $Z_{||}$ of the R_2 - C circuit.

$$\begin{aligned} Z_{||} &= R_2 \parallel \frac{1}{j\omega C} = \frac{R_2(1/j\omega C)}{R_2 + 1/j\omega C} = \frac{R_2}{1 + j\omega CR_2} \\ &= \frac{50}{1 + j10^4 \times 10 \times 10^{-6} \times 50} = \frac{50}{1 + j5} = 1.92 - j9.62 \\ &= 9.81 \angle (-1.3734) \Omega \end{aligned}$$

Next, we determine the equivalent impedance Z_{eq} :

$$\begin{aligned} Z_{\text{eq}} &= R_1 + j\omega L + Z_{||} = 100 + j10^4 \times 10^{-2} + 1.92 - j9.62 \\ &= 101.92 + j90.38 = 136.2 \angle 0.723 \Omega \end{aligned}$$

Is this impedance inductive or capacitive?

Comments: At the frequency used in this example, the circuit has an inductive impedance, since the reactance is positive (or, alternatively, the phase angle is positive).

CHECK YOUR UNDERSTANDING

Compute the equivalent impedance of the circuit of Example 4.14 for $\omega = 1,000$ and $100,000$ rad/s.

Calculate the equivalent series capacitance of the parallel R_2C circuit of Example 4.14 at the frequency $\omega = 10$ rad/s.

Answers: $Z(1,000) = 140 - j10$; $Z(100,000) = 100 + j999$; $X_{||} = 0.25$; $C = 0.4 \text{ F}$

Admittance

In Chapter 3, it was suggested that the solution of certain circuit analysis problems was handled more easily in terms of conductances than resistances. This is true, for example, when one is using node analysis, or in circuits with many parallel elements, since conductances in parallel add as resistors in series do. In AC circuit analysis, an analogous quantity may be defined—the reciprocal of complex impedance. Just as the conductance G of a resistive element was defined as the inverse of the resistance, the **admittance** of a branch is defined as follows:



$$Y = \frac{1}{Z} \quad \text{S} \quad (4.70)$$

Note immediately that whenever Z is purely real, that is, when $Z = R + j0$, the admittance Y is identical to the conductance G . In general, however, Y is the

complex number

$$Y = G + jB \tag{4.71}$$



where G is called the **AC conductance** and B is called the **susceptance**; the latter plays a role analogous to that of reactance in the definition of impedance. Clearly, G and B are related to R and X . However, this relationship is not as simple as an inverse. Let $Z = R + jX$ be an arbitrary impedance. Then the corresponding admittance is

$$Y = \frac{1}{Z} = \frac{1}{R + jX} \tag{4.72}$$

To express Y in the form $Y = G + jB$, we multiply numerator and denominator by $R - jX$:

$$\begin{aligned} Y &= \frac{1}{R + jX} \frac{R - jX}{R - jX} = \frac{R - jX}{R^2 + X^2} \\ &= \frac{R}{R^2 + X^2} - j \frac{X}{R^2 + X^2} \end{aligned} \tag{4.73}$$

and conclude that

$$\begin{aligned} G &= \frac{R}{R^2 + X^2} \\ B &= \frac{-X}{R^2 + X^2} \end{aligned} \tag{4.74}$$

Notice in particular that G is *not the reciprocal of* R in the general case!

Example 4.15 illustrates the determination of Y for some common circuits.

EXAMPLE 4.15 Admittance

Problem

Find the equivalent admittance of the two circuits shown in Figure 4.36.

Solution

Known Quantities: $\omega = 2\pi \times 10^3$ rad/s; $R_1 = 50 \Omega$; $L = 16$ mH; $R_2 = 100 \Omega$; $C = 3 \mu\text{F}$.

Find: The equivalent admittance of the two circuits.

Analysis: Circuit (a): First, determine the equivalent impedance of the circuit:

$$Z_{ab} = R_1 + j\omega L$$

Then compute the inverse of Z_{ab} to obtain the admittance:

$$Y_{ab} = \frac{1}{R_1 + j\omega L} = \frac{R_1 - j\omega L}{R_1^2 + (\omega L)^2}$$

Substituting numerical values gives

$$Y_{ab} = \frac{1}{50 + j2\pi \times 10^3 \times 0.016} = \frac{1}{50 + j100.5} = 3.968 \times 10^{-3} - j7.976 \times 10^{-3} \text{ S}$$

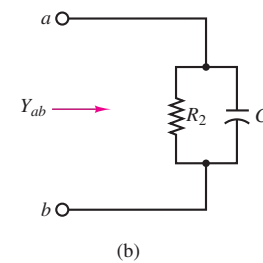
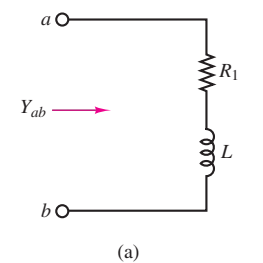

Figure 4.36

Circuit (b): First, determine the equivalent impedance of the circuit:

$$Z_{ab} = R_2 \parallel \frac{1}{j\omega C} = \frac{R_2}{1 + j\omega R_2 C}$$

Then compute the inverse of Z_{ab} to obtain the admittance:

$$Y_{ab} = \frac{1 + j\omega R_2 C}{R_2} = \frac{1}{R_2} + j\omega C = 0.01 + j0.019 \text{ S}$$

Comments: Note that the units of admittance are siemens (S), that is, the same as the units of conductance.

CHECK YOUR UNDERSTANDING

Compute the equivalent admittance of the circuit of Example 4.14.

Answer: $Y_{eq} = 10^{-3} - j4.871 \times 10^{-3} = 5.492 \times 10^{-3} - j4.871 \times 10^{-3}$

Conclusion

In this chapter we have introduced concepts and tools useful in the analysis of AC circuits. The importance of AC circuit analysis cannot be overemphasized, for a number of reasons. First, circuits made up of resistors, inductors, and capacitors constitute reasonable models for more complex devices, such as transformers, electric motors, and electronic amplifiers. Second, sinusoidal signals are ever-present in the analysis of many physical systems, not just circuits. The skills developed in Chapter 4 will be called upon in the remainder of the book. In particular, they form the basis of Chapters 5 and 6. You should have achieved the following objectives, upon completion of this chapter.

1. *Compute currents, voltages, and energy stored in capacitors and inductors.* In addition to elements that dissipate electric power, there exist electric energy storage elements, the capacitor and the inductor.
2. *Calculate the average and root-mean-square value of an arbitrary (periodic) signal.* Energy storage elements are important whenever the excitation voltages and currents in a circuit are time-dependent. Average and rms values describe two important properties of time-dependent signals.
3. *Write the differential equation(s) for circuits containing inductors and capacitors.* Circuits excited by time-dependent sources and containing energy storage (dynamic) circuit elements give rise to differential equations.
4. *Convert time-domain sinusoidal voltages and currents to phasor notation, and vice versa, and represent circuits using impedances.* For the special case of sinusoidal sources, one can use phasor representation to convert sinusoidal voltages and currents into complex phasors, and use the impedance concept to represent circuit elements.

HOMEWORK PROBLEMS

Section 4.1 Energy Storage Circuit Elements

4.1 The current through a 0.5-H inductor is given by $i_L = 2 \cos(377t + \pi/6)$. Write the expression for the voltage across the inductor.

4.2 The voltage across a 100- μ F capacitor takes the following values. Calculate the expression for the current through the capacitor in each case.

- $v_C(t) = 40 \cos(20t - \pi/2)$ V
- $v_C(t) = 20 \sin 100t$ V
- $v_C(t) = -60 \sin(80t + \pi/6)$ V
- $v_C(t) = 30 \cos(100t + \pi/4)$ V

4.3 The current through a 250-mH inductor takes the following values. Calculate the expression for the voltage across the inductor in each case.

- $i_L(t) = 5 \sin 25t$ A
- $i_L(t) = -10 \cos 50t$ A
- $i_L(t) = 25 \cos(100t + \pi/3)$ A
- $i_L(t) = 20 \sin(10t - \pi/12)$ A

4.4 In the circuit shown in Figure P4.4, let

$$i(t) = \begin{cases} 0 & \text{for } -\infty < t < 0 \\ t & \text{for } 0 \leq t < 10 \text{ s} \\ 10 & \text{for } 10 \text{ s} \leq t < \infty \end{cases}$$

Find the energy stored in the inductor for all time.

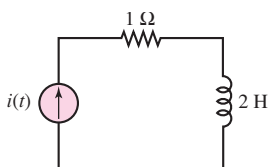

Figure P4.4

4.5 With reference to Problem 4.4, find the energy delivered by the source for all time.

4.6 In the circuit shown in Figure P4.4 let

$$i(t) = \begin{cases} 0 & \text{for } -\infty < t < 0 \\ t & \text{for } 0 \leq t < 10 \text{ s} \\ 20 - t & \text{for } 10 \leq t < 20 \text{ s} \\ 0 & \text{for } 20 \text{ s} \leq t < \infty \end{cases}$$

Find

- The energy stored in the inductor for all time
- The energy delivered by the source for all time

4.7 In the circuit shown in Figure P4.7, let

$$v(t) = \begin{cases} 0 & \text{for } -\infty < t < 0 \\ t & \text{for } 0 \leq t < 10 \text{ s} \\ 10 & \text{for } 10 \text{ s} \leq t < \infty \end{cases}$$

Find the energy stored in the capacitor for all time.

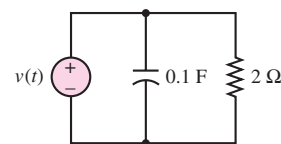

Figure P4.7

4.8 With reference to Problem 4.7, find the energy delivered by the source for all time.

4.9 In the circuit shown in Figure P4.7 let

$$v(t) = \begin{cases} 0 & \text{for } -\infty < t < 0 \\ t & \text{for } 0 \leq t < 10 \text{ s} \\ 20 - t & \text{for } 10 \leq t < 20 \text{ s} \\ 0 & \text{for } 20 \text{ s} \leq t < \infty \end{cases}$$

Find

- The energy stored in the capacitor for all time
- The energy delivered by the source for all time

4.10 Find the energy stored in each capacitor and inductor, under steady-state conditions, in the circuit shown in Figure P4.10.

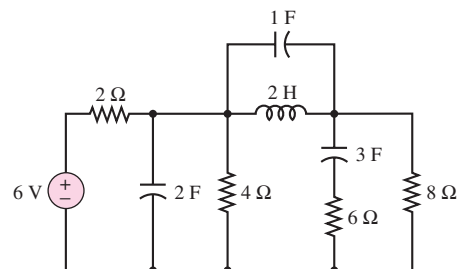

Figure P4.10

4.11 Find the energy stored in each capacitor and inductor, under steady-state conditions, in the circuit shown in Figure P4.11.

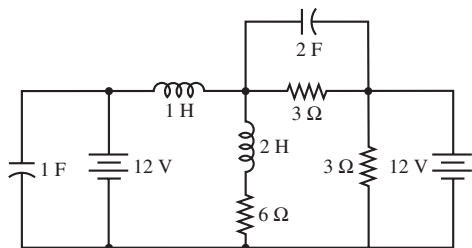

Figure P4.11

4.12 The plot of time-dependent voltage is shown in Figure P4.12. The waveform is piecewise continuous. If this is the voltage across a capacitor and $C = 80 \mu\text{F}$, determine the current through the capacitor. How can current flow “through” a capacitor?

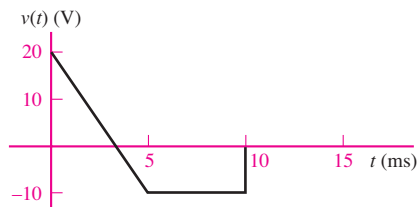

Figure P4.12

4.13 The plot of a time-dependent voltage is shown in Figure P4.12. The waveform is piecewise continuous. If this is the voltage across an inductor $L = 35 \text{ mH}$, determine the current through the inductor. Assume the initial current is $i_L(0) = 0$.

4.14 The voltage across an inductor plotted as a function of time is shown in Figure P4.14. If $L = 0.75 \text{ mH}$, determine the current through the inductor at $t = 15 \mu\text{s}$.

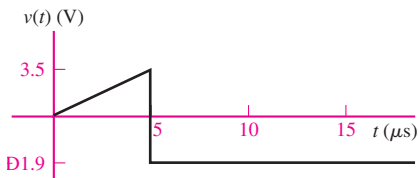

Figure P4.14

4.15 If the waveform shown in Figure P4.15 is the voltage across a capacitor plotted as a function of time with

$$v_{PK} = 20 \text{ V} \quad T = 40 \mu\text{s} \quad C = 680\text{nF}$$

determine and plot the waveform for the current through the capacitor as a function of time.

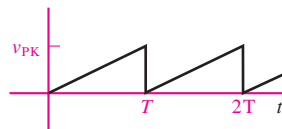

Figure P4.15

4.16 If the current through a $16\text{-}\mu\text{H}$ inductor is zero at $t = 0$ and the voltage across the inductor (shown in Figure P4.16) is

$$v_L(f) = \begin{cases} 0 & t < 0 \\ 3t^2 & 0 < t < 20 \mu\text{s} \\ 1.2 \text{ nV} & t > 20 \mu\text{s} \end{cases}$$

determine the current through the inductor at $t = 30 \mu\text{s}$.

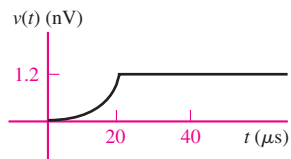

Figure P4.16

4.17 Determine and plot as a function of time the current through a component if the voltage across it has the waveform shown in Figure P4.17 and the component is a

- Resistor $R = 7 \Omega$
- Capacitor $C = 0.5 \mu\text{F}$
- Inductor $L = 7 \text{ mH}$

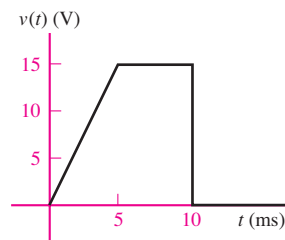

Figure P4.17

4.18 If the plots shown in Figure P4.18 are the voltage across and the current through an ideal capacitor, determine the capacitance.

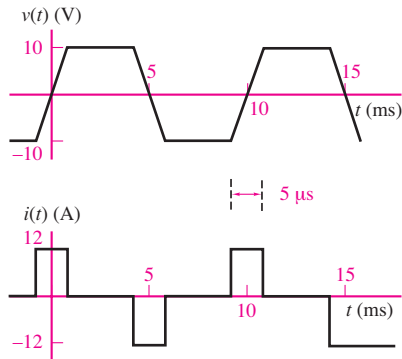

Figure P4.18

4.19 If the plots shown in Figure P4.19 are the voltage across and the current through an ideal inductor, determine the inductance.

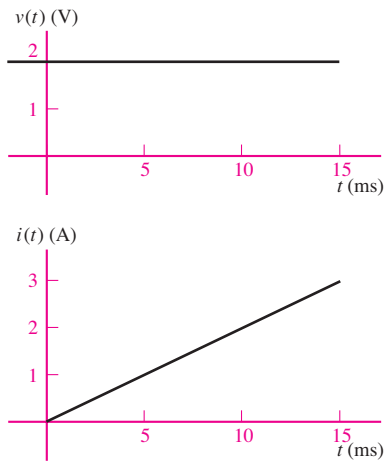

Figure P4.19

4.20 The voltage across and the current through a capacitor are shown in Figure P4.20. Determine the value of the capacitance.

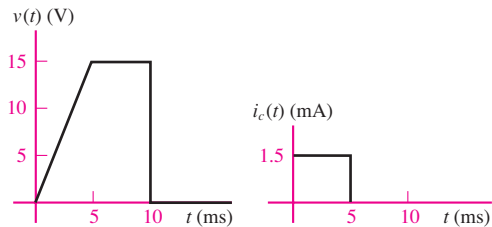

Figure P4.20

4.21 The voltage across and the current through a capacitor are shown in Figure P4.21. Determine the value of the capacitance.

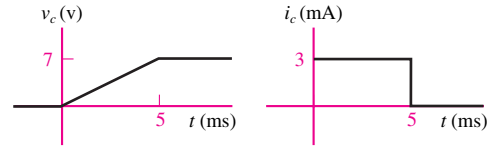

Figure P4.21

4.22 The voltage $v(t)$ shown in Figure P4.22 is applied to a 10-mH inductor. Find the current through the inductor. Assume $i_L(0) = 0$ A.

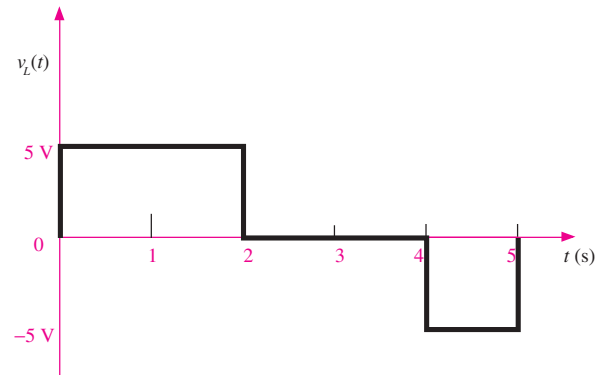

Figure P4.22

4.23 The current waveform shown in Figure P4.23 flows through a 2-H inductor. Plot the inductor voltage $v_L(t)$.

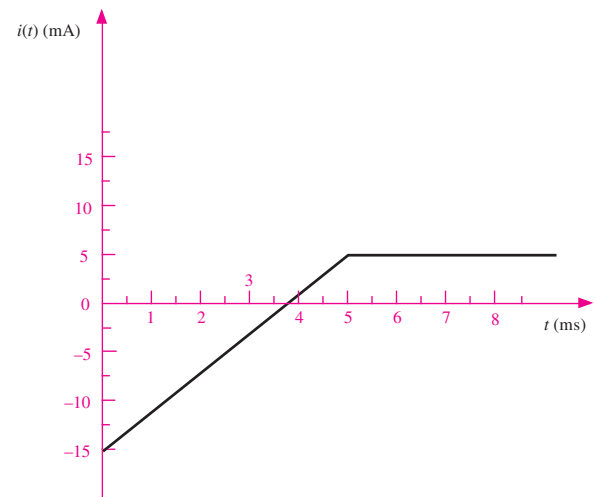

Figure P4.23

4.24 The voltage waveform shown in Figure P4.24 appears across a 100-mH inductor and a 500- μF capacitor. Plot the capacitor and inductor currents, $i_c(t)$ and $i_L(t)$, assuming $i_L(0) = 0$ A.

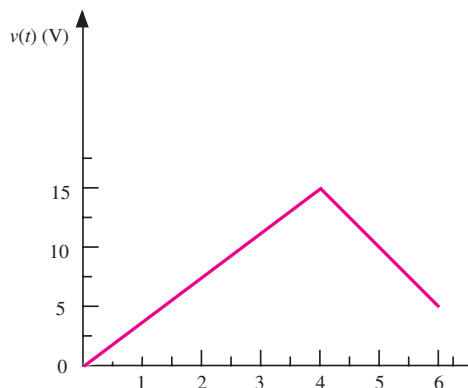

Figure P4.24

4.25 In the circuit shown in Figure P4.25, let

$$i(t) = \begin{cases} 0 & \text{for } -\infty < t < 0 \\ t & \text{for } 0 \leq t < 1 \text{ s} \\ -(t-2) & \text{for } 1 \text{ s} \leq t < 2 \text{ s} \\ 0 & \text{for } 2 \text{ s} \leq t < \infty \end{cases}$$

Find the energy stored in the inductor for all time.

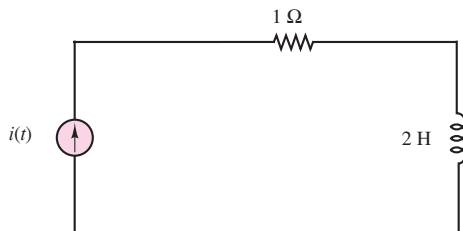

Figure P4.25

4.26 In the circuit shown in Figure P4.26, let

$$v(t) = \begin{cases} 0 & \text{for } -\infty < t < 0 \\ 2t & \text{for } 0 \leq t < 1 \text{ s} \\ -(2t-4) & \text{for } 1 \leq t < 2 \text{ s} \\ 0 & \text{for } 2 \text{ s} \leq t < \infty \end{cases}$$

Find the energy stored in the capacitor for all time.

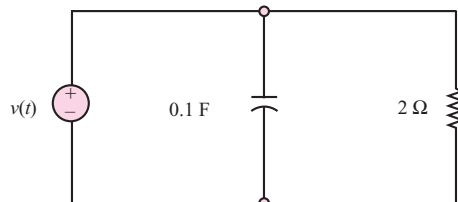

Figure P4.26

4.27 Use the defining law for a capacitor to find the current $i_C(t)$ corresponding to the voltage shown in Figure P4.27. Sketch your result.

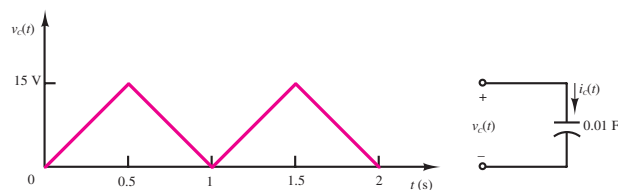

Figure P4.27

4.28 Use the defining law for an inductor to find the current $i_L(t)$ corresponding to the voltage shown in Figure P4.28. Sketch your result.

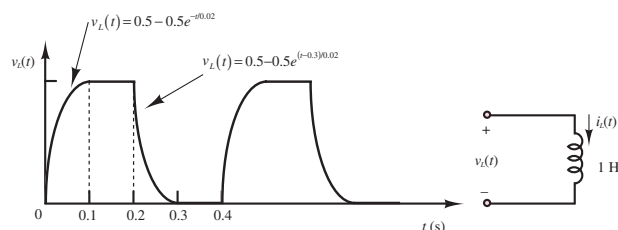

Figure P4.28

Section 4.2 Time-Dependent Signals Sources

4.29 Find the average and rms value of $x(t)$.

$$x(t) = 2 \cos(\omega t) + 2.5$$

4.30 A controlled rectifier circuit is generating the waveform of Figure P4.30 starting from a sinusoidal voltage of 110 V rms. Find the average and rms voltage.

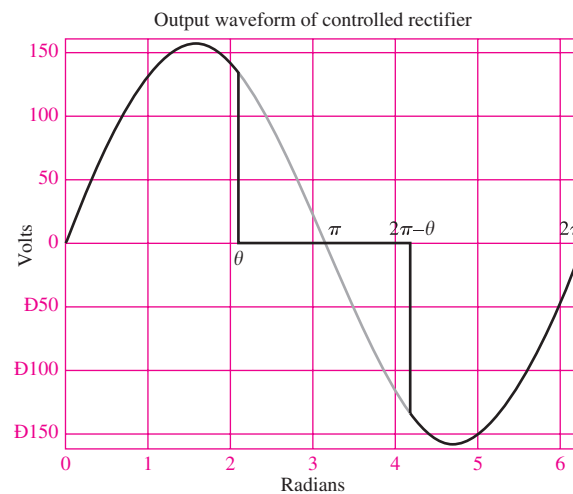

Figure P4.30

- 4.31** With reference to Problem 4.30, find the angle θ that corresponds to delivering exactly one-half of the total available power in the waveform to a resistive load.
- 4.32** Find the ratio between average and rms value of the waveform of Figure P4.32.

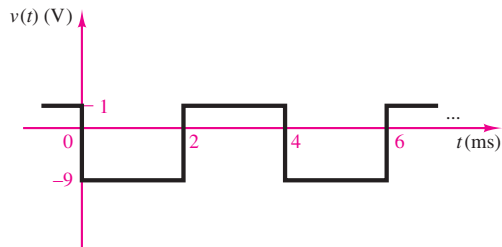

Figure P4.32

- 4.33** Given the current waveform shown in Figure P4.33, find the power dissipated by a $1\text{-}\Omega$ resistor.

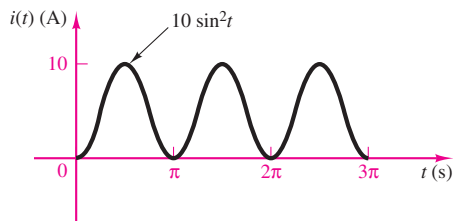

Figure P4.33

- 4.34** Find the ratio between average and rms value of the waveform of Figure P4.34.

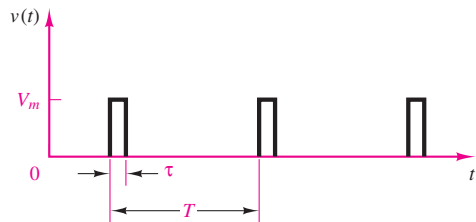

Figure P4.34

- 4.35** Find the rms value of the waveform shown in Figure P4.35.
- 4.36** Determine the rms (or effective) value of

$$v(t) = V_{DC} + v_{AC} = 50 + 70.7 \cos(377t) \text{ V}$$

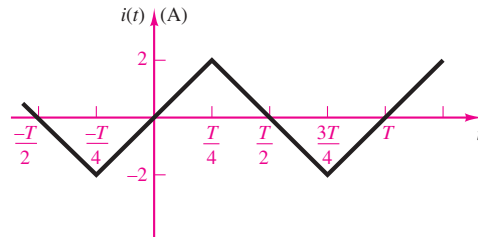

Figure P4.35

- 4.37** Find the phasor form of the following functions:

- $v(t) = 155 \cos(377t - 25^\circ) \text{ V}$
- $v(t) = 5 \sin(1,000t - 40^\circ) \text{ V}$
- $i(t) = 10 \cos(10t + 63^\circ) + 15 \cos(10t - 42^\circ) \text{ A}$
- $i(t) = 460 \cos(500\pi t - 25^\circ) - 220 \sin(500\pi t + 15^\circ) \text{ A}$

- 4.38** Convert the following complex numbers to polar form:

- $4 + j4$
- $-3 + j4$
- $j + 2 - j4 - 3$

- 4.39** Convert the following to polar form and compute the product. Compare the result with that obtained using rectangular form.

- $(50 + j10)(4 + j8)$
- $(j2 - 2)(4 + j5)(2 + j7)$

- 4.40** Complete the following exercises in complex arithmetic.

- Find the complex conjugate of $(4 + j4)$, $(2 - j8)$, $(-5 + j2)$.
- Convert the following to polar form by multiplying the numerator and denominator by the complex conjugate of the denominator and then performing the conversion to polar coordinates:

$$\frac{1 + j7}{4 + j4}, \quad \frac{j4}{2 - j8}, \quad \frac{1}{-5 + j2}$$

- Repeat part b but this time convert to polar coordinates before performing the division.

- 4.41** Convert the following expressions to real-imaginary form: j^j , $e^{j\pi}$.

- 4.42** Given the two voltages $v_1(t) = 10 \cos(\omega t + 30^\circ)$ and $v_2(t) = 20 \cos(\omega t + 60^\circ)$, find $v(t) = v_1(t) + v_2(t)$ using

- Trigonometric identities.
- Phasors.

Section 4.4: Phasor Solution of Circuits with Sinusoidal Excitation

4.43 If the current through and the voltage across a component in an electric circuit are

$$i(t) = 17 \cos(\omega t - \pi/12) \text{ mA}$$

$$v(t) = 3.5 \cos(\omega t + 1.309) \text{ V}$$

where $\omega = 628.3 \text{ rad/s}$, determine

- Whether the component is a resistor, capacitor, or inductor.
- The value of the component in ohms, farads, or henrys.

4.44 Describe the sinusoidal waveform shown in Figure P4.44, using time-dependent and phasor notation.

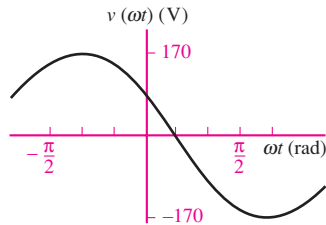

Figure P4.44

4.45 Describe the sinusoidal waveform shown in Figure P4.45, using time-dependent and phasor notation.

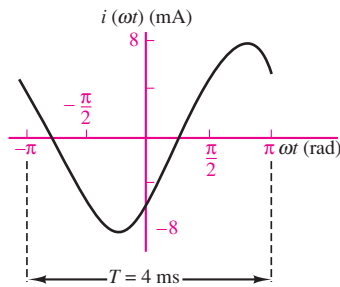

Figure P4.45

4.46 The current through and the voltage across an electrical component are

$$i(t) = I_o \cos\left(\omega t + \frac{\pi}{4}\right) \quad v(t) = V_o \cos \omega t$$

where

$$I_o = 3 \text{ mA} \quad V_o = 700 \text{ mV} \quad \omega = 6.283 \text{ rad/s}$$

- Is the component inductive or capacitive?
- Plot the instantaneous power $p(t)$ as a function of ωt over the range $0 < \omega t < 2\pi$.

- Determine the average power dissipated as heat in the component.
- Repeat parts (b) and (c) if the phase angle of the current is changed to 0° .

4.47 Determine the equivalent impedance in the circuit shown in Figure P4.47:

$$v_s(t) = 7 \cos\left(3,000t + \frac{\pi}{6}\right) \text{ V}$$

$$R_1 = 2.3 \text{ k}\Omega \quad R_2 = 1.1 \text{ k}\Omega$$

$$L = 190 \text{ mH} \quad C = 55 \text{ nF}$$

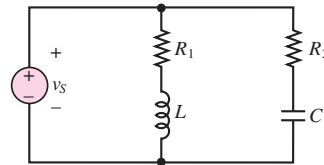

Figure P4.47

4.48 Determine the equivalent impedance in the circuit shown in Figure P4.47:

$$v_s(t) = 636 \cos\left(3,000t + \frac{\pi}{12}\right) \text{ V}$$

$$R_1 = 3.3 \text{ k}\Omega \quad R_2 = 22 \text{ k}\Omega$$

$$L = 1.90 \text{ H} \quad C = 6.8 \text{ nF}$$

4.49 In the circuit of Figure P4.49,

$$i_s(t) = I_o \cos\left(\omega t + \frac{\pi}{6}\right)$$

$$I_o = 13 \text{ mA} \quad \omega = 1,000 \text{ rad/s}$$

$$C = 0.5 \mu\text{F}$$

- State, using phasor notation, the source current.
- Determine the impedance of the capacitor.
- Using phasor notation only and showing all work, determine the voltage across the capacitor, including its polarity.

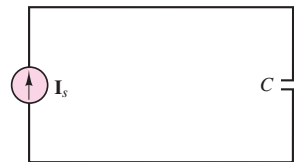

Figure P4.49

4.50 Determine $i_3(t)$ in the circuit shown in Figure P4.50 if

$$i_1(t) = 141.4 \cos(\omega t + 2.356) \text{ mA}$$

$$i_2(t) = 50 \sin(\omega t - 0.927) \text{ mA}$$

$$\omega = 377 \text{ rad/s}$$

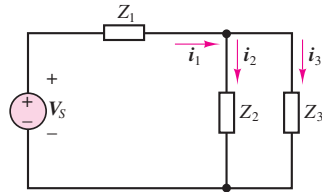

Figure P4.50

4.51 Determine the current through Z_3 in the circuit of Figure P4.51.

$$v_{s1} = v_{s2} = 170 \cos(377t) \text{ V}$$

$$Z_1 = 5.9 \angle 0.122 \Omega$$

$$Z_2 = 2.3 \angle 0 \Omega$$

$$Z_3 = 17 \angle 0.192 \Omega$$

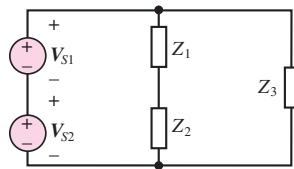

Figure P4.51

4.52 Determine the frequency so that the current I_i and the voltage V_o in the circuit of Figure P4.52 are in phase.

$$Z_s = 13,000 + j\omega 3 \Omega$$

$$R = 120 \Omega$$

$$L = 19 \text{ mH} \quad C = 220 \text{ pF}$$

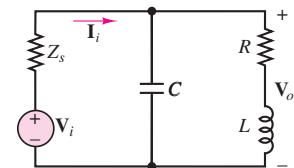

Figure P4.52

4.53 The coil resistor in series with L models the internal losses of an inductor in the circuit of Figure P4.53. Determine the current supplied by the source if

$$v_s(t) = V_o \cos(\omega t + 0)$$

$$V_o = 10 \text{ V} \quad \omega = 6 \text{ M rad/s} \quad R_s = 50 \Omega$$

$$R_c = 40 \Omega \quad L = 20 \mu\text{H} \quad C = 1.25 \text{ nF}$$

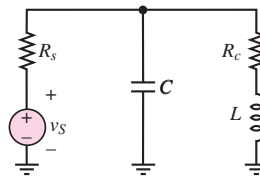

Figure P4.53

4.54 Using phasor techniques, solve for the current in the circuit shown in Figure P4.54.

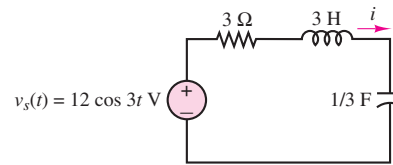

Figure P4.54

4.55 Using phasor techniques, solve for the voltage v in the circuit shown in Figure P4.55.

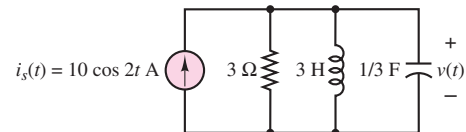

Figure P4.55

4.56 Solve for I_1 in the circuit shown in Figure P4.56.

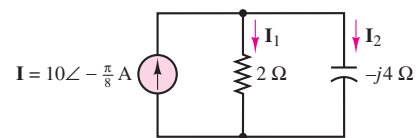

Figure P4.56

4.57 Solve for V_2 in the circuit shown in Figure P4.57. Assume $\omega = 2$.

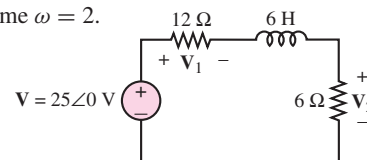

Figure P4.57

4.58 With reference to Problem 4.55, find the value of ω for which the current through the resistor is maximum.

4.59 Find the current through the resistor in the circuit shown in Figure P4.59.

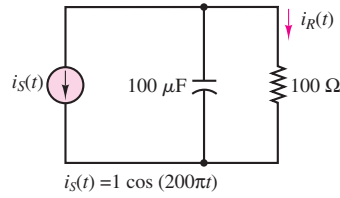

Figure P4.59

4.60 Find $v_{out}(t)$ for the circuit shown in Figure P4.60.

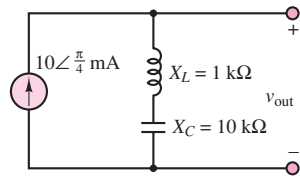

Figure P4.60

4.61 For the circuit shown in Figure P4.61, find the impedance Z , given $\omega = 4$ rad/s.

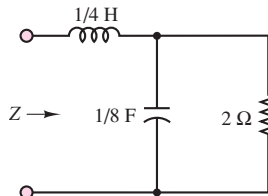

Figure P4.61

4.62 Find the sinusoidal steady-state outputs for each of the circuits shown in Figure P4.62.

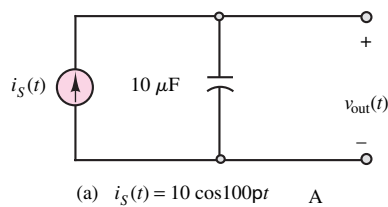
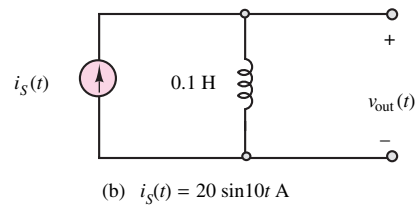
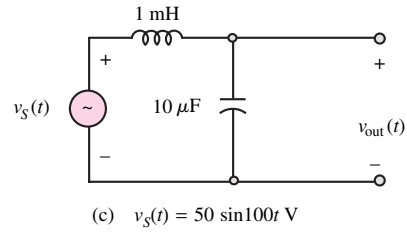

Figure P4.62 (Continued)



(b) $i_S(t) = 20 \sin 10t$ A



(c) $v_S(t) = 50 \sin 100t$ V

Figure P4.62

4.63 Determine the voltage across the inductor in the circuit shown in Figure P4.63.

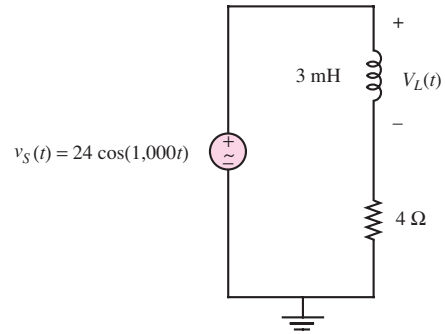

Figure P4.63

4.64 Determine the current through the capacitor in the circuit shown in Figure P4.64.

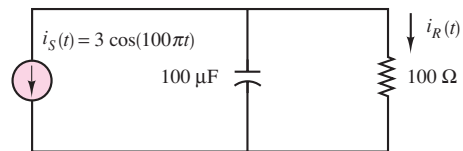

Figure P4.64

4.65 For the circuit shown in the Figure P4.65, find the frequency that causes the equivalent impedance to appear purely resistive.

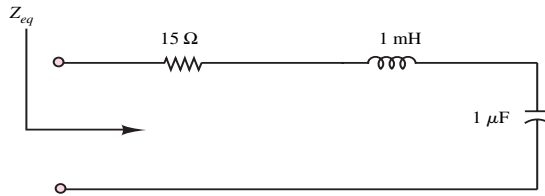

Figure P4.65

4.66

- Find the equivalent impedance Z_L shown in Figure P4.66(a), as seen by the source, if the frequency is 377 rad/s.
- If we wanted the source to see the load as completely resistive, what value of capacitance should we place between the terminals a and b as shown in Figure P4.66(b)? *Hint:* Find an expression for the equivalent impedance Z_L , and then find C so that the phase angle of the impedance is zero.

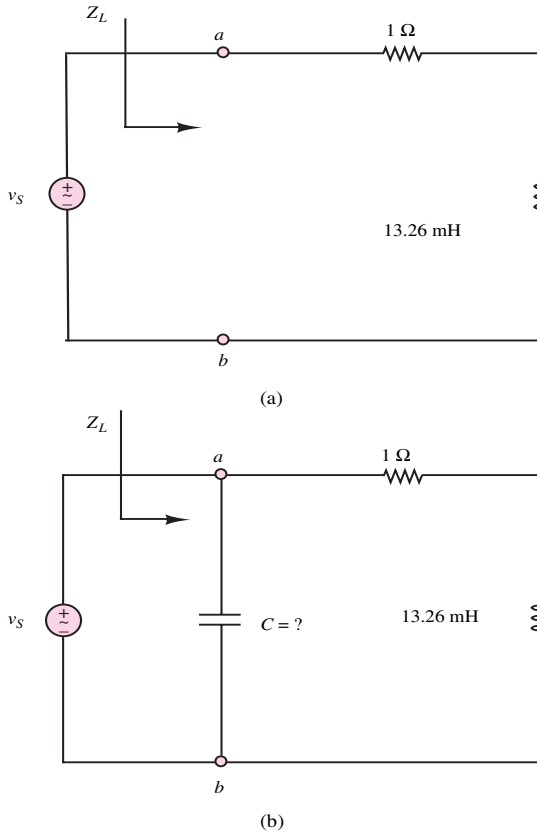

Figure P4.66

- What is the actual impedance that the source sees with the capacitor included in the circuit?

4.67 The capacitor model we have used so far has been treated as an ideal circuit element. A more accurate model for a capacitor is shown in Figure P4.67. The ideal capacitor, C , has a large “leakage” resistance, R_C , in parallel with it. R_1 and R_2 represent the lead wire resistances, and L_1 and L_2 represent the lead wire inductances.

- If $C = 1 \mu\text{F}$, $R_C = 100 \text{ M}\Omega$, $R_1 = R_2 = 1 \mu\Omega$ and $L_1 = L_2 = 0.1 \mu\text{H}$, find the equivalent impedance seen at the terminals a and b as a function of frequency ω .
- Find the range of frequencies for which Z_{ab} is capacitive, i.e., $X_{ab} > 10|R_{ab}$.

Hint: Assume that R_C is much greater than $1/\omega C$ so that you can replace R_C by an infinite resistance in part b.

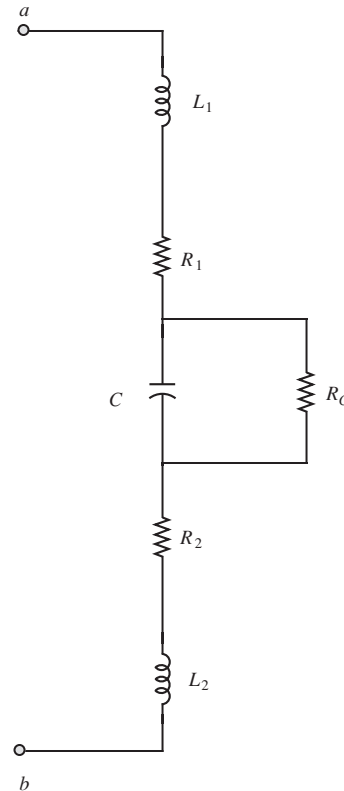

Figure P4.67

