

Sample Solutions Manual
for
System Dynamics, Second Edition
by
William J. Palm III
University of Rhode Island

Published by McGraw-Hill

This is a sample of the solutions provided in the manual available to instructors. Note that

- A solution is provided for every problem, and all solutions are typeset.
- There is only one problem per page.
- Problem solutions display the intermediate steps, not just the final answer.
- Free body diagrams are shown in problems requiring derivation of equations of motion. Circuit diagrams and block diagrams are shown in solutions where needed.
- Solutions display the required MATLAB code along with the resulting plots.
- Problems dealing with Simulink display the required Simulink diagram.
- Frequency response and root locus plots are shown when needed.

In the solutions manual there is only one problem per page. Problem solutions display the intermediate steps, not just the final answer.

Problem 3.24 The denominator roots are $s = -3$ and $s = -5$, which are distinct. Factor the denominator so that the highest coefficients of s in each factor are unity:

$$X(s) = \frac{7s + 4}{2s^2 + 16s + 30} = \frac{1}{2} \left[\frac{7s + 4}{(s + 3)(s + 5)} \right]$$

The partial-fraction expansion has the form

$$X(s) = \frac{1}{2} \left[\frac{7s + 4}{(s + 3)(s + 5)} \right] = \frac{C_1}{s + 3} + \frac{C_2}{s + 5}$$

Using the coefficient formula (3.5-4), we obtain

$$C_1 = \lim_{s \rightarrow -3} \left[(s + 3) \frac{7s + 4}{2(s + 3)(s + 5)} \right] = \lim_{s \rightarrow -3} \left[\frac{7s + 4}{2(s + 5)} \right] = -\frac{17}{4}$$

$$C_2 = \lim_{s \rightarrow -5} \left[(s + 5) \frac{7s + 4}{2(s + 3)(s + 5)} \right] = \lim_{s \rightarrow -5} \left[\frac{7s + 4}{2(s + 3)} \right] = \frac{31}{4}$$

Using the LCD method we have

$$\begin{aligned} \frac{1}{2} \frac{7s + 4}{(s + 3)(s + 5)} &= \frac{C_1}{s + 3} + \frac{C_2}{s + 5} = \frac{C_1(s + 5) + C_2(s + 3)}{(s + 3)(s + 5)} \\ &= \frac{(C_1 + C_2)s + 5C_1 + 3C_2}{(s + 3)(s + 5)} \end{aligned}$$

Comparing numerators, we see that $C_1 + C_2 = 7/2$ and $5C_1 + 3C_2 = 4/2 = 2$, which give $C_1 = -17/4$ and $C_2 = 31/4$.

The inverse transform is

$$x(t) = C_1 e^{-3t} + C_2 e^{-5t} = -\frac{17}{4} e^{-3t} + \frac{31}{4} e^{-5t}$$

In this example the LCD method requires more algebra, including the solution of two equations for the two unknowns C_1 and C_2 .

Free body diagrams are shown in problems requiring derivation of equations of motion. Circuit diagrams and block diagrams are shown in solutions where needed.

Problem 2.31 See the following figure. Summing forces in the x and y directions gives:

$$ma_{Gx} = \mu_s N_B - mg \sin \theta \quad (1)$$

$$N_A + N_B = mg \cos \theta \quad (2)$$

Summing moments about G :

$$N_A L_A - N_B L_B + \mu_s N_B H = 0 \quad (3)$$

Solve (2) and (3):

$$N_A = \frac{mg \cos \theta (\mu_s H - L_B)}{\mu_s H - L_A - L_B} = \frac{16,677 \cos \theta (\mu_s - 2.1)}{\mu_s - 4.6}$$

$$N_B = -\frac{mg L_A \cos \theta}{\mu_s H - L_A - L_B} = \frac{40,025 \mu_s \cos \theta}{4.6 - \mu_s}$$

The maximum acceleration is, from (1),

$$a_{Gx} = \frac{23.544 \mu_s \cos \theta}{4.6 - \mu_s} - 9.81 \sin \theta$$

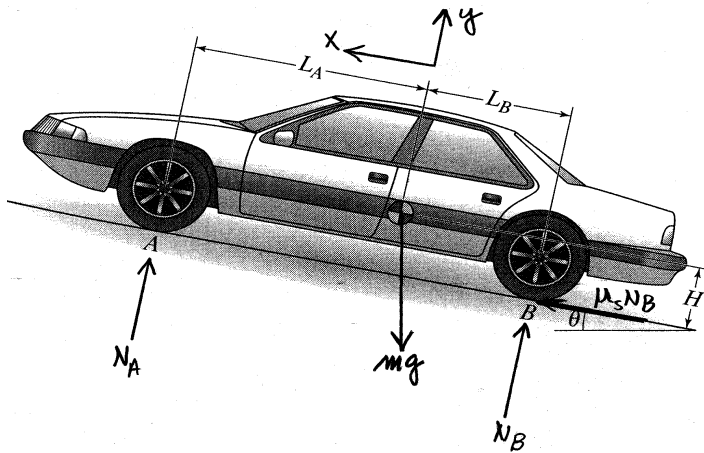

Figure : for Problem 2.31

Problems dealing with Simulink display the required Simulink diagram.

Problem 5.39 The model is shown in the following figure. Set the Start and End of the Dead Zone to -0.5 and 0.5 respectively. Set the Sine Wave block to use simulation time. Set the Amplitude to 2 and the Frequency to 4. In the Math Function block select the square function. Set the Initial condition of the Integrator to 1. You can plot the results by typing

```
>>plot(tout,simout),xlabel('t'),ylabel('x')
```

Using a stop time of 3 results in an error message that indicates that Simulink is having trouble finding a small enough step size to handle the rapidly decreasing solution. By experimenting with the stop time, we find that, to two decimal places, a stop time of 1.49 will not generate an error.

This model is unstable, and the output $x \rightarrow -\infty$ if the time span is long enough. We can see this by writing the equation as (not including the effect of the dead zone)

$$\dot{x} = 2 \sin 4t - 10x^2$$

Once x drops below $\sqrt{2/10}$, \dot{x} remains negative and thus x continues to decrease through negative values.

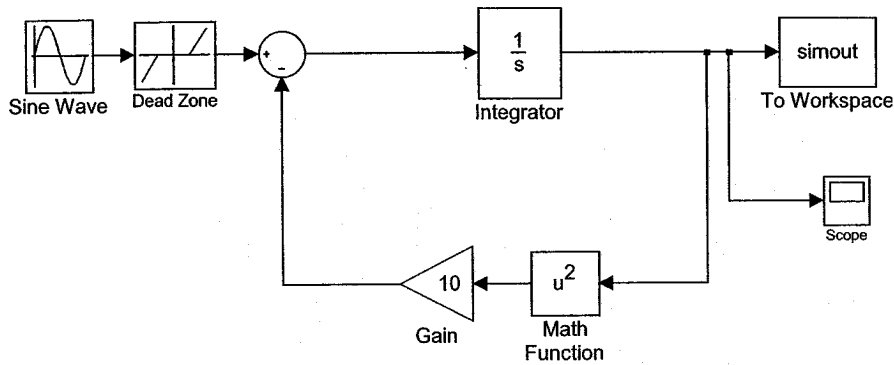

Figure : for Problem 5.39.

Solutions display the required MATLAB code along with the resulting plots.

Problem 6.47 The script file is

```
KT = 0.2; Kb = 0.2; c = 5e-4; Ra = 0.8; La = 4e-3; I = 5e-4;
den = [La*I, Ra*I + c*La, c*Ra + Kb*KT];
% Speed transfer function:
sys1 = tf(KT, den);
% Current transfer function:
sys2 = tf([I, c], den);
% Applied voltage
t = [0:0.001:0.05]; va = 10*ones(size(t));
% Speed:
om = lsim(sys1, va, t);
% Current:
ia = lsim(sys2, va, t);
subplot(2,1,1), plot(t, om), xlabel('t (s)'), ylabel('\omega (rad/s)')
subplot(2,1,2), plot(t, ia), xlabel('t (s)'), ylabel('i_a (A)')
```

The plot is shown in the following figure. The peak current is approximately 8 A. The more accurate value of 8.06 A can be found with the `lsim(sys2, va, t)` function by right-clicking on the plot, selecting Characteristics, then Peak Response.

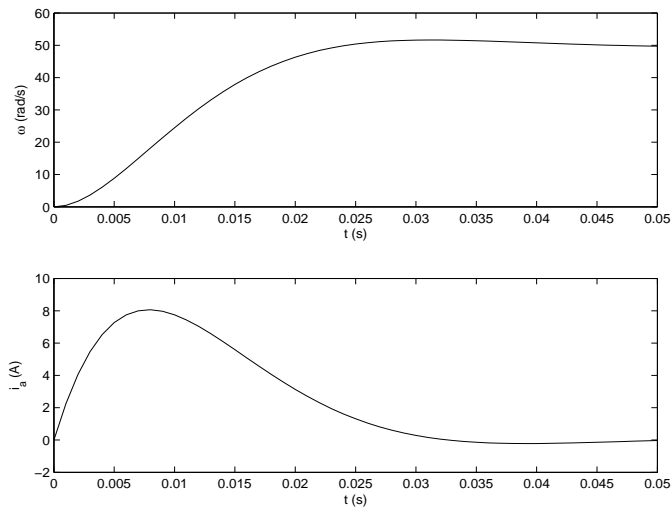

Figure : for Problem 6.47

Frequency response plots are shown when needed.

Problem 8.47 The program is given below, along with the resulting plot. The resonant frequency is 2.51×10^4 rad/s. By moving the cursor along the plot we can determine the points at which the curve is 3 dB below the peak. These frequencies are 2.39×10^4 and 2.61×10^4 , so the bandwidth is $(2.61 - 2.39) \times 10^4 = 2.2 \times 10^3$ rad/sec.

```
m = 0.002;k = 1e6;Kf = 20;Kb = 15;R = 10;L = 0.001;  
sys = tf(Kf, [m*L,m*R,k*L+Kf*Kb,k*R]);  
bode(sys)
```

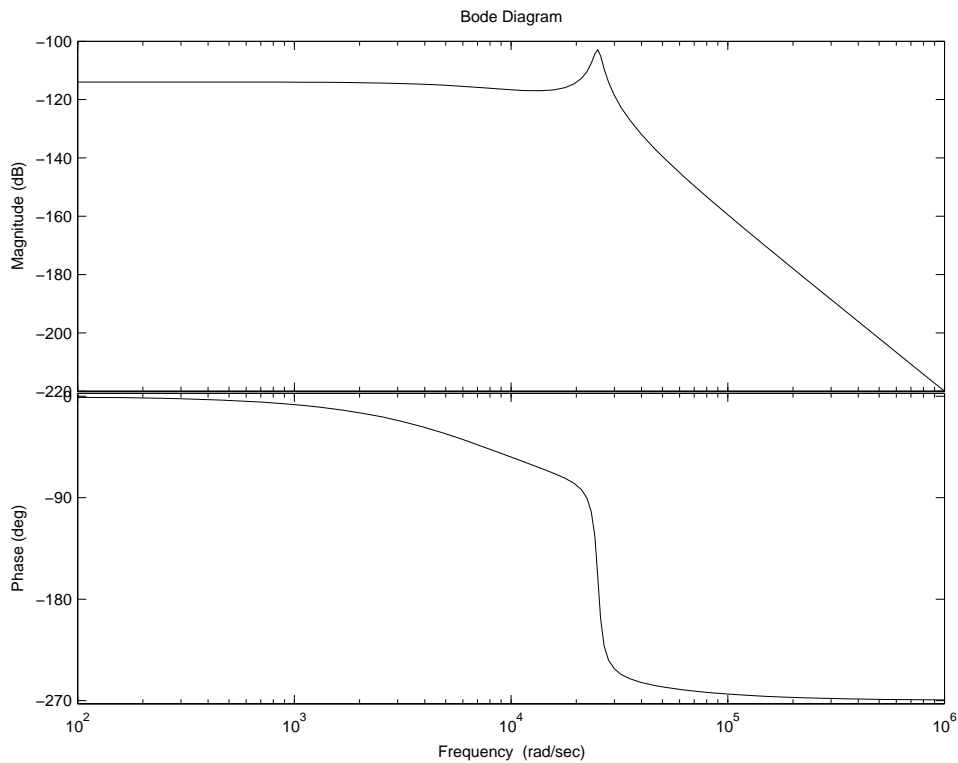

Figure : Plot for Problem 8.47

Root locus plots are shown when needed.

Problem 11.57 The characteristic equation is $10s^3 + (2 + K_D)s^2 + K_P s + K_I = 0$. With $K_P = 55$ and $K_D = 58$, we have $10s^3 + 60s^2 + 55s + K_I = 0$, or

$$1 + \frac{K_I}{10} \frac{1}{s^3 + 6s^2 + 5.5s} = 0$$

The root locus gain is $K = K_I/10$. In MATLAB type

```
sys = tf(1, [1, 6, 5.5, 0]);  
rlocus(sys), axis equal
```

The plot follows. In Example 10.7.4, $K_I = 25$. This gives $\zeta = 0.707$ and $\tau = 2$. The plot shows that to reduce the error by increasing K_I , the dominant time constant will become larger and the damping ratio will decrease, making the system slower and more oscillatory. Moving the cursor along the plot shows that if we decrease the error by half by doubling K_I to 50, the new damping ratio will be approximately 0.44 and the new time constant will be approximately $1/0.43 = 2.3$.

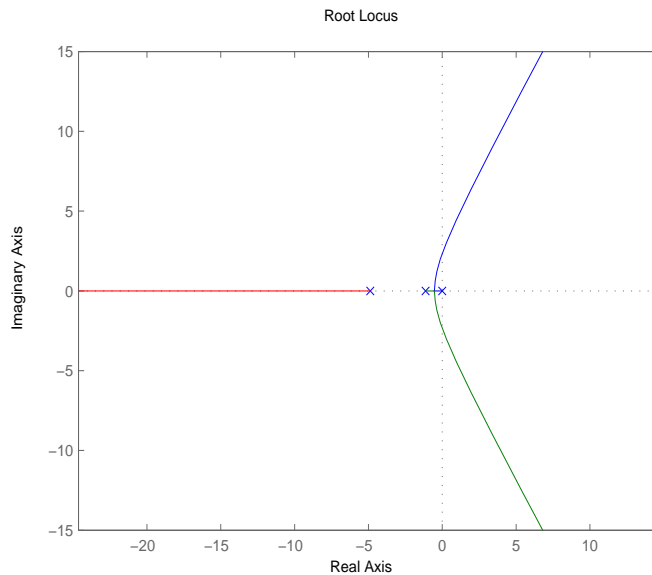

Figure : for Problem 11.57.